

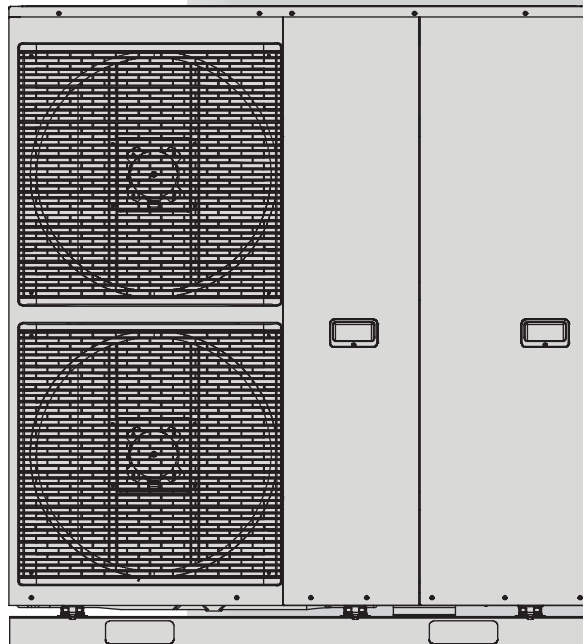

Residential Air-Water Heat Pump Installation and Operation Manual Mono Bloc Unit RAH040



WARNING

This service information is designed for experienced repair technicians only and is not designed for use by the general public. It does not contain warnings or cautions to advise non-technical individuals of potential dangers in attempting to service a product. Products powered by electricity should be serviced or repaired only by experienced professional technicians. Any attempt to service or repair the products dealt with in this service information by anyone else could result in serious injury or death.

Save this manual for future reference.

Contents

| | |
|---|------------|
| 1. SAFETY PRECAUTIONS | 3-5 |
| 2. PRECAUTION FOR USING R32 REFRIGERANT | 6-12 |
| 3. FEATURES | 13 |
| 4. LOCATION OF CONTROLS AND COMPONENTS | |
| Indoor Unit..... | 14 |
| Menu Functions Table..... | 17-27 |
| 5. DIAGRAMS | 28 |
| 6. INSTALLATION | |
| Handling of the Mono Bloc Unit | 29 |
| Piping Installation | 31 |
| Maintenance | 37 |
| 7. MAINTENANCE GUIDE | |
| Maintenance Menu..... | 53 |
| 8. TROUBLESHOOTING GUIDE | |
| Refrigeration Cycle System..... | 54 |
| Relationship between the Condition of the Air-to-Water Heatpump Indoor and Outdoor Units and Pressure and Electric Current..... | 55 |
| Breakdown Self Diagnosis Function | 55 |
| Error Codes Table | 57-59 |
| Revision Notes | Back Cover |

1 Safety Precautions

Read the following “SAFETY PRECAUTIONS” carefully before installation of (Mono bloc) Air-to-Water Heatpump system (hereafter referred to as “Mono bloc unit”). Electrical works and water installation works must be done by licensed electrician and licensed water system installer respectively. Be sure to use the correct rating and main circuit for the model to be installed. The caution items stated here must be followed because these important contents are related to safety. The meaning of each indication used is as below. Incorrect installation due to ignorance or negligence of the instructions will cause harm or damage, and the seriousness is classified by the following indications.

⚠ WARNING WARNING indicates a potentially hazardous situation which, if not avoided, could result in death or serious injury.

⚠ CAUTION CAUTION indicates the possibility of causing injury or damage to properties only.

















The items to be followed are classified by the symbols:

- ⊘ Symbol with white background denotes item that is PROHIBITED.
- ⚠ Symbol with dark background denotes item that must be carried out.

NOTICE NOTICE indicates special instructions on installation, operation, or maintenance that are important but not related to personal injury or property damage.

| ⚠ WARNING | |
|--|---|
| This appliance is not intended for use by persons (including children) with reduced physical, sensory or mental capabilities, or lack of experience and knowledge, unless they have been given supervision or instruction concerning use of the appliance by a person responsible for their safety. Children should be supervised to ensure that they do not play with the appliance. | |
| Do not use means to accelerate the defrosting process or to clean, other than those recommended by the manufacturer. Any unfit method or using incompatible material may cause product damage, burst and serious injury. | ⊘ |
| Do not install Mono bloc unit near handrail of balcony. When installing Mono bloc unit at balcony of high rise building, child may climb up to Mono bloc unit and cross over the handrail and causing accident. | ⊘ |
| Do not use unspecified cord, modified cord, joint cord or extension cord for power supply cord. Do not share the single outlet with other electrical appliances. Poor contact, poor insulation or over current will cause electrical shock or fire. | ⊘ |
| Do not tie up the power supply cord into a bundle by band. Abnormal temperature rise on power supply cord may happen. | ⊘ |
| Do not insert your fingers or other objects into the unit, high speed rotating fan may cause injury. | ⊘ |
| Do not sit or step on the unit, you may fall down accidentally. | ⊘ |
| Keep plastic bag (packaging material) away from small children, it may cling to nose and mouth and prevent breathing. | ⊘ |
| Do not purchase unauthorized electrical parts for installation, service, maintenance and etc.. They might cause electrical shock or fire. | ⊘ |
| Do not pierce or burn as the appliance is pressurized. Do not expose the appliance to heat, flame, sparks, or other sources of ignition. Else, it may explode and cause injury or death. | ⊘ |
| This Mono bloc unit is a multi supply appliance. All circuits must be disconnected before accessing the unit terminals. | ⊘ |
| Do not modify the wiring of Mono bloc unit for installation of other components (i.e. heater, etc). Overloaded wiring or wire connection points may cause electrical shock or fire. | ⊘ |
| Do not add or replace refrigerant other than specified type. It may cause product damage, burst and injury etc. | ⊘ |
| For electrical work, follow the national regulation, legislation and this installation instructions. An independent circuit and single outlet must be used. If electrical circuit capacity is not enough or defect found in the electrical work, it will cause electrical shock or fire. | ⚠ |















1 Safety Precautions

|  WARNING | |
|---|---|
| For water circuit installation work, follow to relevant North American and national regulations and local plumbing and building regulation codes. |  |
| Engage a qualified installer or technician or specialist for installation. If installation done by the user is incorrect, it will cause water leakage, electrical shock or fire. |  |
| Install according to this installation instructions strictly. If installation is defective, it will cause water leakage, electrical shock or fire. |  |
| Only use the supplied or specified installation parts. Else, it may causes Mono bloc unit vibrate, fall, water leakage, electrical shock or fire. |  |
| Install at a flat, strong and firm location which is able to withstand the Mono bloc unit's weight. If the location is slanting, or strength is not enough the set will fall and cause injury. |  |
| Wire routing must be properly arranged so that control board cover is fixed properly. If control board cover is not fixed perfectly, it will cause fire or electrical shock. |  |
| This equipment is strongly recommended to be installed with Residual Current Device (RCD) on-site according to the respective national wiring rules or country-specific safety measures in terms of residual current. |  |
| The unit is only for use in a closed water system. Utilization in an open water system may lead to excessive corrosion of the water piping and risk of incubating bacteria colonies, particularly Legionella, in water. |  |
| If there is any doubt about the installation procedure or operation, always contact the a qualified installer or technician for advice and information. |  |
| Select a location where in case of water leakage, the leakage will not cause damage to other properties. |  |
| When installing electrical equipment in a wooden building that uses metal lath or wire lath, contact between the building and electrical components is not allowed. This is in accordance with electrical facility standards. An insulator must be installed in between the electrical components and the building. |  |
| This installation may be subjected to building regulation approval applicable to respective country that may require to notify the local authority before installation. |  |
| Any work carried out on the Mono bloc unit after removing any panel which is secured by screws, must be carried out under the supervision of a qualified installer or technician and licensed installation contractor. |  |
| Be aware that refrigerants may not contain an odor. |  |
| This equipment must be properly connected to the ground. Earth line must not be connected to gas pipe, water pipe, earth of lightning rod and telephone. Otherwise, it may cause electrical shock in case of equipment breakdown or insulation breakdown. |  |

FCC Responsible Party:

Lochinvar LLC.
 300 Maddox-Simpson Pkwy, Lebanon, TN 37090
 (800) 722-2101
 lochinvar@lochinvar.com

1 Safety Precautions

|  | |
|--|---|
| Do not install the Mono bloc unit at place where leakage of flammable gas may occur. In case gas leaks and accumulates at surrounding of the Mono bloc unit, it may cause fire. |  |
| Do not release refrigerant during piping work for installation, re-installation and during repairing a refrigeration parts. Take care of the liquid refrigerant, it may cause frostbite. |  |
| Make sure the insulation of power supply cord does not contact hot part (i.e. refrigerant piping, water piping) to prevent from insulation failure (melt). |  |
| Do not touch the sharp aluminium fin; sharp parts may cause injury. |  |
| Do not apply excessive force to water pipes that may damage the pipes. If water leakage occurs, it will cause flooding and damage to other properties. |  |
| Carry out drainage piping as mentioned in installation instructions. If drainage is not perfect, water leakage may happen and may cause damage to properties of the user. |  |
| The piping installation work must be flushed before the Mono bloc unit is connected to remove contaminants. Contaminants may damage the Mono bloc unit components. |  |
| Select an installation location which is easy for maintenance. Incorrect installation, service or repair of this Mono bloc unit may increase the risk of rupture and this may result in loss damage or injury and/or property. |  |
| Ensure the correct polarity is maintained throughout all wiring. Otherwise, it will cause electrical shock or fire. |  |
| <p>Power supply connection to Mono bloc unit.</p> <ul style="list-style-type: none"> • Power supply point should be in easily accessible place for power disconnection in case of emergency. • Must follow local national wiring standard, regulation and this installation instruction. • Strongly recommended to make permanent connection to a circuit breaker. It must be a double pole switch with a minimum 1/8 inch gap. <ul style="list-style-type: none"> - Power supply 1: Use approved 30A circuit breaker - Power supply 2: Use approved 30A circuit breaker |  |
| After installation, the installer is obliged to verify correct operation of the Mono bloc unit. Check the connection point for water leakage during test run. If leakage occurs, it will cause damage to other properties. |  |
| Keep any required ventilation openings clear of obstruction. |  |
| <p>Installation work.</p> <p>Four or more people are required to carry out the installation work. The weight of Mono bloc unit might cause injury if carried by less than four people.</p> |  |

Federal Communications Commission Interference Statement

This device complies with part 15 of the FCC Rules. Operation is subject to the following two conditions: (1) This device may not cause harmful interference, and (2) this device must accept any interference received, including interference that may cause undesired operation.

This equipment has been tested and found to comply with the limits for a Class B digital device, pursuant to part 15 of the FCC Rules. These limits are designed to provide reasonable protection against harmful interference in a residential installation. This equipment generates, uses and can radiate radio frequency energy and, if not installed and used in accordance with the instructions, may cause harmful interference to radio communications. However, there is no guarantee that interference will not occur in a particular installation.

If this equipment does cause harmful interference to radio or television reception, which can be determined by turning the equipment off and on, the user is encouraged to try to correct the interference by one or more of the following measures:













- Reorient or relocate the receiving antenna.
- Increase the separation between the equipment and receiver.
- Connect the equipment into an outlet on a circuit different from that to which the receiver is connected.
- Consult the dealer or an experienced radio/TV technician for help.

FCC Caution: To ensure continued compliance, follow the attached installation instruction. Any changes or modifications not expressly approved by the party responsible for compliance could void the user's authority to operate the equipment.

Industry Canada Notice
CAN ICES-3(B)/NMB-3(B)

2 Precaution for Using R32 Refrigerant

The basic installation work procedures are the same as conventional refrigerant (R410A, R22) models. However, pay careful attention to the following points:

|  WARNING | |
|--|---|
| <p>Since the working pressure is higher than that of refrigerant R22 models, some of the piping and installation and service tools are special.</p> <p>Especially, when replacing a refrigerant R22 model with a new refrigerant R32 model, always replace the conventional piping with the R32 and R410A piping on the outdoor unit side.</p> <p>For R32 and R410A, the same pipe can be used.</p> |  |
| <p>The mixing of different refrigerants within a system is prohibited. Models that use refrigerant R32 and R410A have a different charging port thread diameter to prevent erroneous charging with refrigerant R22 and for safety. Therefore, check beforehand. [The charging port thread diameter for R32 and R410A is 1/2 inch.]</p> |  |
| <p>Ensure that foreign matter (oil, water, etc.) does not enter the piping.</p> |  |
| <p>Operation, maintenance, repairing and refrigerant recovery should be carried out by trained and certified personnel in the use of flammable refrigerants and as recommended by the manufacturer. Any personnel conducting an operation, servicing or maintenance on a system or associated parts of the equipment should be trained and certified.</p> |  |
| <p>Any part of refrigerating circuit (evaporators, air coolers, AHU, condensers or liquid receivers) or piping should not be located in the proximity of heat sources, open flames, operating gas appliance or an operating electric heater.</p> |  |
| <p>The user/owner or their authorized representative shall regularly check the alarms, mechanical ventilation and detectors, at least once a year, where as required by national regulations, to ensure their correct functioning.</p> |  |
| <p>A logbook shall be maintained. The results of these checks shall be recorded in the logbook.</p> |  |
| <p>In case of ventilations in occupied spaces shall be checked to confirm no obstruction.</p> |  |
| <p>Before a new refrigerating system is put into service, the person responsible for placing the system in operation should ensure that trained and certified operating personnel are instructed on the basis of the instruction manual about the construction, supervision, operation and maintenance of the refrigerating system, as well as the safety measures to be observed, and the properties and handling of the refrigerant used.</p> |  |
| <p>The general requirement of trained and certified personnel are indicated as below:</p> <ul style="list-style-type: none"> a) Knowledge of legislation, regulations and standards relating to flammable refrigerants; and, b) Detailed knowledge of and skills in handling flammable refrigerants, personal protective equipment, refrigerant leakage prevention, handling of cylinders, charging, leak detection, recovery and disposal; and, c) Able to understand and to apply in practice the requirements in the national legislation, regulations and Standards; and, d) Continuously undergo regular and further training to maintain this expertise. |  |
| <p>Protect the refrigerating system from accidental rupture due to moving furniture or reconstruction activities.</p> |  |
| <p>To ensure no leaking, refrigerant joints shall be tightness tested. The test method shall have a sensitivity of 0.17 ounces per year of refrigerant or better under a pressure of at least 0.25 times the maximum allowable pressure (>151 Psi, max 624 Psi). No leak shall be detected.</p> |  |

2 Precaution for Using R32 Refrigerant



| | |
|---------------------------------|---|
| INSTALLATION (Space) | <ul style="list-style-type: none"> • Must comply with national gas regulations, state municipal rules and legislation. Notify relevant authorities in accordance with all applicable regulations. • Must ensure mechanical connections be accessible for maintenance purposes. • In cases that require mechanical ventilation, the ventilation openings shall be kept clear of obstruction. • When disposal of the product, do follow to the precautions in the RECOVERY section of this manual and comply with national regulations. • Always contact to local municipal offices for proper handling. |
| SERVICING | <p>Service personnel</p> <ul style="list-style-type: none"> • Any qualified person who is involved with working on or breaking into a refrigerant circuit should hold a current valid certificate from an industry-accredited assessment authority, which authorizes their competence to handle refrigerants safely in accordance with an industry recognized assessment specification. • Servicing shall only be performed as recommended by the equipment manufacturer. Maintenance and repair requiring the assistance of other skilled personnel shall be carried out under the supervision of the person competent in the use of flammable refrigerants. • Servicing shall be performed only as recommended by the manufacturer. • The system is inspected, regularly supervised and maintained by a trained and certified service personnel who is employed by the person user or party responsible. • Ensure refrigerant charge not to leak. <p>Work</p> <ul style="list-style-type: none"> • Prior to beginning work on systems containing flammable refrigerants, safety checks are necessary to ensure that the risk of ignition is minimized. • For repair to the refrigerating system, the precautions in the Servicing section under Work and Checks to Electrical devices must be followed before conducting work on the system. • Work shall be undertaken under a controlled procedure so as to minimize the risk of a flammable gas or vapor being present while the work is being performed. • All maintenance staff and others working in the local area shall be instructed and supervised on the nature of work being carried out. • Avoid working in confined spaces. Always ensure away from source, at least 6 1/2 feet of safety distance, or zoning of free space area of at least 6 1/2 feet in radius. • Wear appropriate protective equipment, including respiratory protection, as conditions warrant. • Keep all sources of ignition and hot metal surfaces away. <p>Checking for presence of refrigerant</p> <ul style="list-style-type: none"> • The area shall be checked with an appropriate refrigerant detector prior to and during work, to ensure the technician is aware of potentially flammable atmospheres. • Ensure that the leak detection equipment being used is suitable for use with flammable refrigerants, i.e. non sparking, adequately sealed or intrinsically safe. • In case of leakage/spillage happened, immediately ventilate area and stay upwind and away from spill/release. • In case of leakage/spillage happened, do notify persons downwind of the leaking/spill, isolate immediate hazard area and keep unauthorized personnel out. <p>Presence of fire extinguisher</p> <ul style="list-style-type: none"> • If any hot work is to be conducted on the refrigeration equipment or any associated parts, appropriate fire extinguishing equipment shall be available at hand. • Have a dry powder or CO2 fire extinguisher adjacent to the charging area. |

2 Precaution for Using R32 Refrigerant

CAUTION

SERVICING

No ignition sources

- No person carrying out work in relation to a refrigerating system which involves exposing any pipe work that contains or has contained flammable refrigerant shall use any sources of ignition in such a manner that it may lead to the risk of fire or explosion. He/She must not be smoking when carrying out such work.
- All possible ignition sources, including cigarette smoking, should be kept sufficiently far away from the site of installation, repairing, removing and disposal, during which flammable refrigerant can possibly be released to the surrounding space.
- Prior to work taking place, the area around the equipment is to be surveyed to make sure that there are no flammable hazards or ignition risks.
- “No Smoking” signs shall be displayed.

Ventilated area

- Ensure that the area is in the open or that it is adequately ventilated before breaking into the system or conducting any hot work.
- A degree of ventilation shall continue during the period that the work is carried out.
- The ventilation should safely disperse any released refrigerant and preferably expel it externally into the atmosphere.

Refrigeration Equipment Checks

- Where electrical components are being changed, they shall be fit for the purpose and to the correct specification.
- At all times the manufacturer’s maintenance and service guidelines shall be followed.
- If in doubt consult the manufacturer’s technical department for assistance.
- The following checks shall be applied to installations using flammable refrigerants:
 - The ventilation machinery and outlets are operating adequately and are not obstructed.
 - Marking to the equipment continues to be visible and legible. Markings and signs that are illegible shall be corrected.

Checks to electrical devices

- Repair and maintenance to electrical components shall include initial safety checks and component inspection procedures.
- Initial safety checks shall include but not limit to:
 - That capacitors are discharged: this shall be done in a safe manner to avoid possibility of sparking.
 - That there is no live electrical components and wiring are exposed while charging, recovering or purging the system.
 - That there is continuity of earth-ground bonding.
- At all times the manufacturer’s maintenance and service guidelines shall be followed.
- If in doubt consult the manufacturer’s technical department for assistance.
- If a fault exists that could compromise safety, then no electrical supply shall be connected to the circuit until it is satisfactorily dealt with.
- If the fault cannot be corrected immediately but it is necessary to continue operation, an adequate temporary solution shall be used.
- The owner of the equipment must be informed or reported so all parties are advised thereafter.

Repairs to sealed components

- Sealed electrical components shall be replaced.

2 Precaution for Using R32 Refrigerant

|  | |
|---|---|
| REPAIR TO SAFE COMPONENTS | <ul style="list-style-type: none"> • Intrinsically safe components must be replaced. |
| CABLING | <ul style="list-style-type: none"> • Check that cabling will not be subject to wear, corrosion, excessive pressure, vibration, sharp edges or any other adverse environmental effects. • The check shall also take into account the effects of aging or continual vibration from sources such as compressors or fans. |
| DETECTION OF FLAMMABLE REFRIGERANTS | <ul style="list-style-type: none"> • Under no circumstances shall potential sources of ignition be used in the searching or detection of refrigerant leaks. • A halide torch (or any other detector using a naked flame) shall not be used. |
| LEAK DETECTION | <p>The following leak detection methods are deemed acceptable for all refrigerant systems:</p> <ul style="list-style-type: none"> • No leaks shall be detected when using detection equipment with a sensitivity of 0.17 ounces per year of refrigerant or better under a pressure of at least 0.25 times the maximum allowable pressure (>151 Psi, max 624 Psi) for example, a universal sniffer. • Electronic leak detectors may be used to detect flammable refrigerants, but the sensitivity may not be adequate, or may need re-calibration. • (Detection equipment shall be calibrated in a refrigerant-free area.) • Ensure that the detector is not a potential source of ignition and is suitable for the refrigerant used. • Leak detection equipment shall be set at a percentage of the LFL of the refrigerant and shall be calibrated to the refrigerant employed and the appropriate percentage of gas (25 % maximum) is confirmed. • Leak detection fluids are also suitable for use with most refrigerants, for example, bubble method and fluorescent method agents. • The use of detergents containing chlorine shall be avoided as the chlorine may react with the refrigerant and corrode the copper pipe-work. • If a leak is suspected, all naked flames shall be removed/extinguished. • If a leakage of refrigerant is found which requires brazing, all of the refrigerant shall be recovered from the system, or isolated (by means of shut off valves) in a part of the system remote from the leak. The precautions in the Removal and Evacuation section of this manual must be followed to remove the refrigerant. |

2 Precaution for Using R32 Refrigerant

|  CAUTION | |
|---|--|
| REMOVAL AND EVACUATION | <ul style="list-style-type: none"> • When breaking into the refrigerant circuit to make repairs – or for any other purpose – conventional procedures shall be used. However, it is important that best practice is followed since flammability is a consideration. The following procedure shall be adhered to: <ol style="list-style-type: none"> 1. Safely remove refrigerant following local and national regulations 2. Evacuate 3. Purge the circuit with inert gas 4. Evacuate 5. Continuously flush with inert gas when using flame to open circuit 6. Open the circuit • The refrigerant charge shall be recovered into the correct recovery cylinders if venting is not allowed by local and national codes. • The system shall be purged with OFN to render the appliances safe. (remark: OFN = oxygen free nitrogen, type of inert gas) • This process may need to be repeated several times. • Compressed air or oxygen shall not be used for this task. • Purging shall be achieved by breaking the vacuum in the system with OFN and continuing to fill until the working pressure is achieved, then venting to atmosphere, and finally pulling down to a vacuum. • This process shall be repeated until no refrigerant is within the system. • When the final OFN charge is used, the system shall be vented down to atmospheric pressure to enable work to take place. • This operation is absolutely vital if brazing operations on the pipe work are to take place. • Ensure that the outlet for the vacuum pump is not close to any ignition sources and there is ventilation available. |
| CHARGING PROCEDURES | <ul style="list-style-type: none"> • In addition to conventional charging procedures, the following requirements shall be followed: <ul style="list-style-type: none"> - Ensure that contamination of different refrigerants does not occur when using charging equipment. - Hoses or lines shall be as short as possible to minimize the amount of refrigerant contained in them. - Cylinders shall be kept in an appropriate position according to the instructions. - Ensure that the refrigerating system is earthed prior to charging the system with refrigerant. - Label the system when charging is complete (if not already). - Extreme care shall be taken not to over fill the refrigeration system. • Prior to recharging the system it shall be pressure tested with OFN (refer to LEAK DETECTION). • The system shall be leak tested on completion of charging but prior to commissioning. • A follow up leak test shall be carried out prior to leaving the site. • Electrostatic charge may accumulate and create a hazardous condition when charging and discharging the refrigerant. • To avoid fire or explosion, dissipate static electricity during transfer by grounding and bonding containers and equipment before charging/discharging. |

2 Precaution for Using R32 Refrigerant

|  CAUTION | |
|---|--|
| DECOMMISSIONING | <ul style="list-style-type: none"> • Before carrying out this procedure, it is essential that the technician is completely familiar with the equipment and all its details. • It is recommended good practice that all refrigerants are recovered safely. • Prior to the task being carried out, an oil and refrigerant sample shall be taken in case analysis is required prior to re-use of recovered refrigerant. • It is essential that electrical power is available before the task is commenced. <ul style="list-style-type: none"> a) Become familiar with the equipment and its operation. b) Isolate system electrically. c) Before attempting the procedure ensure that: <ul style="list-style-type: none"> - mechanical handling equipment is available, if required, for handling refrigerant cylinders; - all personal protective equipment is available and being used correctly; - the recovery process is supervised at all times by a competent person; - recovery equipment and cylinders conform to the appropriate standards. d) Pump down refrigerant system, if possible. e) If a vacuum is not possible, make a manifold so that refrigerant can be removed from various parts of the system. f) Make sure that cylinder is situated on the scales before recovery takes place. g) Start the recovery machine and operate in accordance with manufacturer's instructions. h) Do not over fill cylinders. (No more than 80% volume liquid charge). i) Do not exceed the maximum working pressure of the cylinder, even temporarily. j) When the cylinders have been filled correctly and the process completed, make sure that the cylinders and the equipment are removed from site promptly and all isolation valves on the equipment are closed off. k) Recovered refrigerant shall not be charged into another refrigeration system unless it has been cleaned and checked. • Electrostatic charge may accumulate and create a hazardous condition when charging or discharging the refrigerant. • To avoid fire or explosion, dissipate static electricity during transfer by grounding and bonding containers and equipment before charging/discharging. |
| LABELLING | <ul style="list-style-type: none"> • Equipment shall be labelled stating that it has been de-commissioned and emptied of refrigerant. • The label shall be dated and signed. • Ensure that there are labels on the equipment stating the equipment contains flammable refrigerant. |

2 Precaution for Using R32 Refrigerant

⚠ CAUTION

RECOVERY

- When removing refrigerant from a system, either for servicing or decommissioning, it is recommended good practice that all refrigerants are removed safely.
- When transferring refrigerant into cylinders, ensure that only appropriate refrigerant recovery cylinders are employed.
- Ensure that the correct number of cylinders for holding the total system charge are available.
- All cylinders to be used are designated for the recovered refrigerant and labelled for that refrigerant (i.e. special cylinders for the recovery of refrigerant).
- Cylinders shall be complete with pressure relief valve and associated shut-off valves in good working order.
- Recovery cylinders are evacuated and, if possible, cooled before recovery occurs.
- The recovery equipment shall be in good working order with a set of instructions concerning the equipment that is at hand and shall be suitable for the recovery of flammable refrigerants. If in doubt, the manufacturer should be consulted.
- In addition, a set of calibrated weighing scales shall be available and in good working order.
- Hoses shall be complete with leak-free disconnect couplings and in good condition.
- The recovered refrigerant shall be processed according to local legislation in the correct recovery cylinder, and the relevant waste transfer note arranged. Do not mix refrigerants in recovery units and especially not in cylinders.
- If compressors or compressor oils are to be removed, ensure that they have been evacuated to an acceptable level to make certain that flammable refrigerant does not remain within the lubricant.
- The compressor body shall not be heated by an open flame or other ignition sources to accelerate this process. When oil is drained from a system, it shall be carried out safely.

3 Features

- **Inverter Technology**
 - Energy saving
- **High Efficiency**
- **Compact Design**
- **Environment Protection**
 - Non-ozone depletion substances refrigerant (R32)
- **Easy to use control panel**
- **Weekly Timer**
- **Quality Improvement**
 - Random auto restart after power failure for safety restart operation
 - Gas leakage protection
 - Prevent compressor reverse cycle
 - Inner protector to protect compressor
- **Serviceability Improvement**
 - Breakdown Self Diagnosis function
 - System Status Check Buttons for servicing purpose
 - System Pumpdown Button for servicing purpose
 - Front maintenance design for outdoor unit
- **Operation Condition**

| | Heating (Circuit) | Cooling (Circuit) |
|--|--|-------------------|
| Water outlet temperature °F (Min. / Max) | 68 / 131 (Below Ambient -4 °F)*2 68 / 140 (Ambient 5~32°F or Above Ambient 77°F)*3 68 / 149 (Ambient 41~68°F)*3*4 | 41 / 68 |
| Outdoor ambient temperature °F (Min. / Max) | -4 / 95 | 50 / 109 |

NOTICE : When the outdoor temperature is out of the range in the table, the heating capacity will drop significantly and the mono bloc unit may stop operating for its protection.

The unit will restart automatically after the outdoor temperature returns to the specified range.

*2 Between outdoor ambient 5°F and -4°F, the water outlet temperature gradually decreases from 140°F to 131°F.

*3 Between outdoor ambient 41°F and 32°F, the water outlet temperature gradually decreases from 149°F to 140°F.

*3 Between outdoor ambient 68°F and 77°F, the water outlet temperature gradually decreases from 149°F to 140°F.

*4 Only when ΔT is set to 27°F, the set temperature above 140°F will take effect.

4 Location of Controls and Components

Indoor Unit

Remote control buttons and display

Figure 4-1 Control buttons

| Buttons / Indicator | |
|---------------------|---|
| ① | Quick Menu button |
| ② | Back button Returns to the previous screen |
| ③ | LCD Display |
| ④ | Main Menu button For function setup |
| ⑤ | ON/OFF button Starts/Stops operation |
| ⑥ | Operation indicator Illuminates during operation, blinks during alarm. |

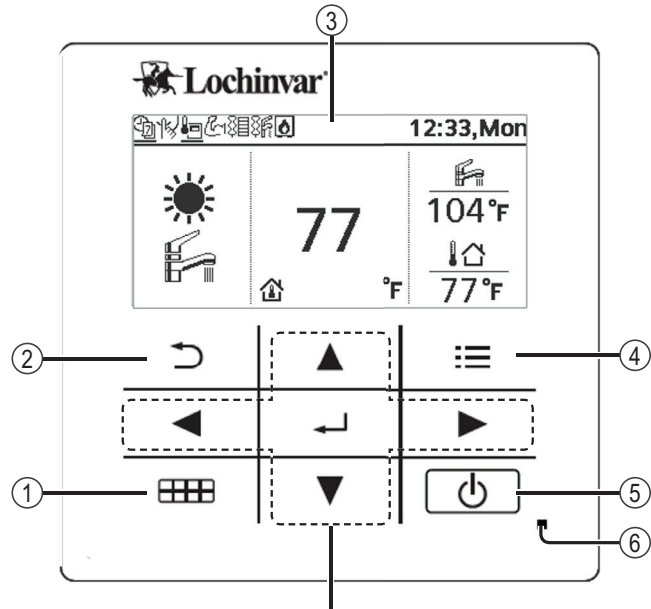

 Press center

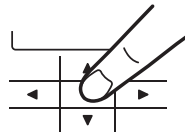

 No glove

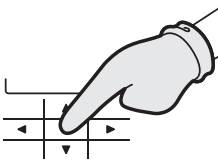

 No pen

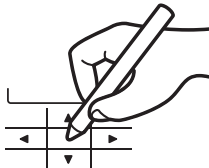

Cross key buttons
Selects an item.

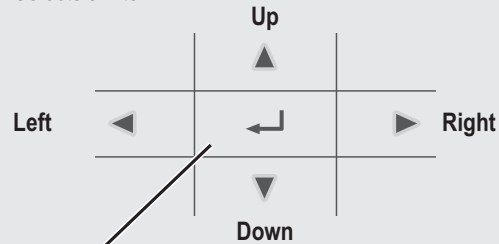

Enter button
Fixes the selected content.

4 Location of Controls and Components

Figure 4-2 Display

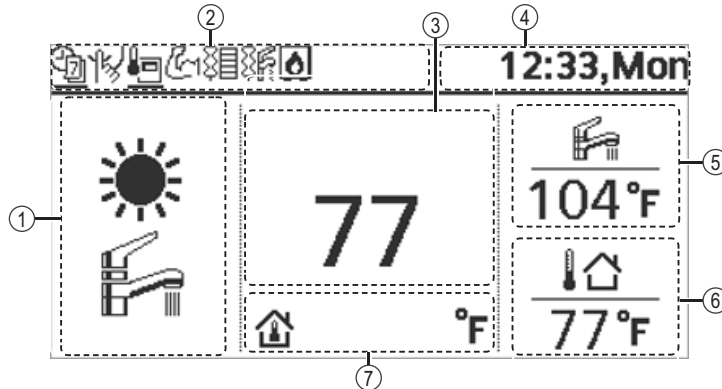

Display

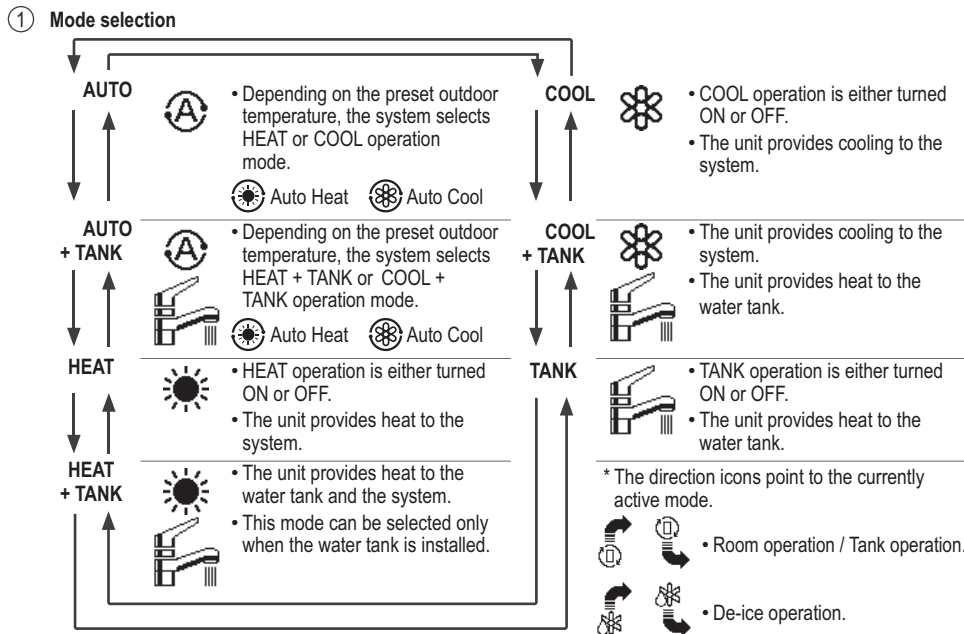

- ② Operation icons
- The status of operation is displayed. Icon will not display (under operation OFF screen) whenever operation is OFF except weekly timer.
- Holiday operation status
 - Weekly Timer operation status
 - Quiet operation status
 - Zone:Room Thermostat → Internal sensor status
 - Powerful operation status
 - Room Heater status
 - Tank Heater status
 - Backup Boiler

- ③ Temperature of each zone
- ④ Time and day
- ⑤ Water Tank temperature
- ⑥ Outdoor temperature
- ⑦ Sensor type/Set temperature type icons
- | | |
|--|----------------------------|
| Water Temperature → Compensation curve | Water Temperature → Direct |
| Room Thermostat → External | Room Thermostat → Internal |

4 Location of Controls and Components

Initialization

Before customizing the various menu settings, please initiate the Remote Controller by selecting the desired language of operation and entering the date and time correctly. When power is turned on for the first time, it will show the Settings Screen automatically. It can also be set from Personal Settings of the menu.

Figure 4-3 Settings

Selecting the language

Wait while the display is initializing.
When initializing screen ends, it turns to normal screen.
When any button is pressed, language setting screen appears.

- ① Scroll with ▼ and ▲ to select the language.
- ② Press ↵ to confirm the selection.

Setting the clock

- ① Select with ▼ or ▲ how to display the time, either 24h or am/pm format (for example, 15:00 or 3:00 pm).
- ② Press ↵ to confirm the selection.
- ③ Use ▼ and ▲ to select year, month, day, hour and minutes. (Select and move with ▶ and press ↵ to confirm.)
- ④ Once the time is set, time and day will appear on the display even if the Remote Controller is turned OFF.

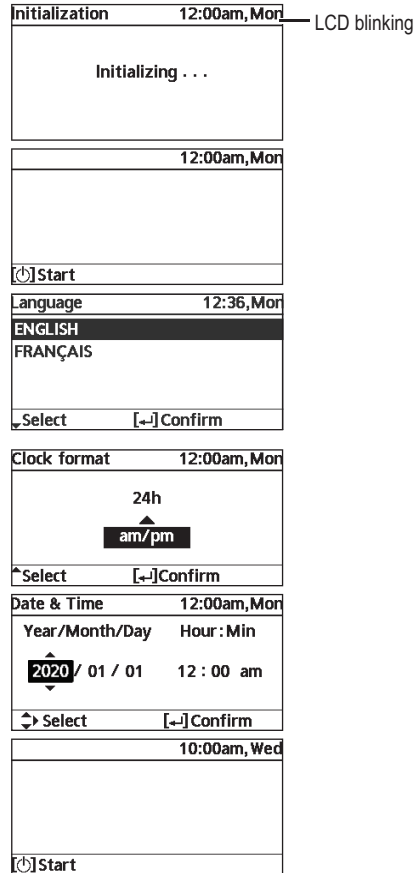

Quick Menu

After the initial settings have been completed, you can select a quick menu from the following options and edit the setting:

Figure 4-4 Quick menu

- ① Press [Grid Icon] to display the quick menu.

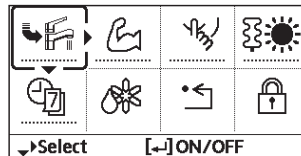

- ② Use ▲ ▼ ◀ ▶ to select menu.
- ③ Press ↵ to turn on/off the select menu.

4 Location of Controls and Components

Menus for User

Select menu and determine settings according to the system available in the household. All initial settings must be done by a qualified installer or service technician. It is recommended that all alterations of the initial settings are also done by an authorised dealer or a specialist.

- After initial installation, you may manually adjust the settings.
- The initial setting remains active until the user changes it.
- The Remote Controller can be used for multiple installations.
- Ensure the operation indicator is OFF before setting.
- The system may not work properly if set wrongly.

Please consult a qualified installer or service technician.

Figure 4-5 Navigation

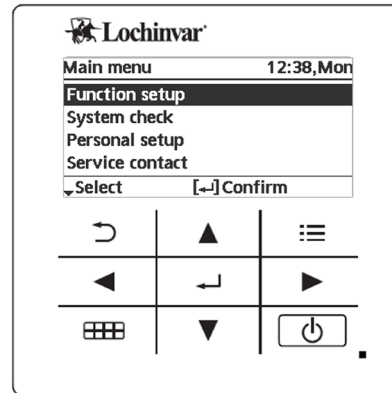

To display <Main Menu>: [Menu Icon]
 To select menu: [Up] [Down] [Left] [Right]
 To confirm the selected content: [Enter]

Table 4-1 Menu Functions

| Menu Function | Description | Default Setting | Display | | | | | | | | | | | | | | | | | | | | | | | | | | | | | |
|----------------------|---|--|---|---|------|-------|-------|---------|-----|-----|---------|------------|----|----------|---|--|--|-------|-------------|----|--|------|--|--|-------|-------------|----|--|------|--|--|--|
| FUNCTION SETUP | Weekly Timer | <ul style="list-style-type: none"> •To set up to 6 patterns of operation on a daily basis. •Once the weekly timer is set up, User can edit from Quick Menu. •Disabled if Heat-Cool SW is select “Yes” or if Force Heater is on. | <p>Timer setup Select day of the week and set the patterns needed. (Time / Operation / ON/OFF / Mode)</p> <p>Timer copy Select the day of the week</p> | <p>Weekly timer 12:42, Mon</p> <table border="1"> <tr> <th>Sun</th> <th>Mon</th> <th>Tue</th> <th>Wed</th> <th>Thu</th> <th>Fri</th> <th>Sat</th> </tr> <tr> <td>1. 8:00 ON</td> <td>☀️</td> <td></td> <td></td> <td></td> <td></td> <td>104°F</td> </tr> <tr> <td>2. 12:00 ON</td> <td>☀️</td> <td></td> <td>77°F</td> <td></td> <td></td> <td>104°F</td> </tr> <tr> <td>3. 13:00 ON</td> <td>☀️</td> <td></td> <td>77°F</td> <td></td> <td></td> <td></td> </tr> </table> <p>↔Day ↘Pattern [←]Edit</p> | Sun | Mon | Tue | Wed | Thu | Fri | Sat | 1. 8:00 ON | ☀️ | | | | | 104°F | 2. 12:00 ON | ☀️ | | 77°F | | | 104°F | 3. 13:00 ON | ☀️ | | 77°F | | | |
| | Sun | Mon | Tue | Wed | Thu | Fri | Sat | | | | | | | | | | | | | | | | | | | | | | | | | |
| | 1. 8:00 ON | ☀️ | | | | | 104°F | | | | | | | | | | | | | | | | | | | | | | | | | |
| | 2. 12:00 ON | ☀️ | | 77°F | | | 104°F | | | | | | | | | | | | | | | | | | | | | | | | | |
| | 3. 13:00 ON | ☀️ | | 77°F | | | | | | | | | | | | | | | | | | | | | | | | | | | | |
| Holiday Timer | <ul style="list-style-type: none"> •To save energy, a holiday period may be set to either turn OFF the system or lower the temperature during the period. •Weekly timer setting may be temporarily disabled during Holiday timer setting but it will restart once the Holiday timer is completed. | <p>OFF</p> <p>ON Holiday start and end.</p> | <p>ON OFF</p> <p>Holiday: End 10:34am, Mon</p> <p>Year/Month/Day Hour : Min</p> <p>2020 / 01 / 07 10 : 00 am</p> <p>↕Select [←]Confirm</p> | | | | | | | | | | | | | | | | | | | | | | | | | | | | | |
| Quiet Timer | <ul style="list-style-type: none"> •To operate quietly during the preset period. •6 patterns may be set. •Level 0 means the mode is off. | <p>Time to Start Quiet Date and time</p> <p>Level of Quietness 0-3</p> | <p>Quiet 10:34am, Mon</p> <table border="1"> <tr> <th>Pattern</th> <th>Time</th> <th>Level</th> </tr> <tr> <td>1</td> <td>8:00 am</td> <td>0</td> </tr> <tr> <td>2</td> <td>5:00 pm</td> <td>1</td> </tr> <tr> <td>3</td> <td>11:00 pm</td> <td>3</td> </tr> </table> <p>↕Select [←]Edit</p> | Pattern | Time | Level | 1 | 8:00 am | 0 | 2 | 5:00 pm | 1 | 3 | 11:00 pm | 3 | | | | | | | | | | | | | | | | | |
| Pattern | Time | Level | | | | | | | | | | | | | | | | | | | | | | | | | | | | | | |
| 1 | 8:00 am | 0 | | | | | | | | | | | | | | | | | | | | | | | | | | | | | | |
| 2 | 5:00 pm | 1 | | | | | | | | | | | | | | | | | | | | | | | | | | | | | | |
| 3 | 11:00 pm | 3 | | | | | | | | | | | | | | | | | | | | | | | | | | | | | | |
| Room Heater | <ul style="list-style-type: none"> •To set the room heater ON or OFF. | OFF | <p>ON OFF</p> | | | | | | | | | | | | | | | | | | | | | | | | | | | | | |
| Tank Heater | <ul style="list-style-type: none"> •To set the tank heater ON or OFF. •Available only if connected to the tank. | OFF | <p>ON OFF</p> | | | | | | | | | | | | | | | | | | | | | | | | | | | | | |

4 Location of Controls and Components

Table 4-1 Menu Functions continued

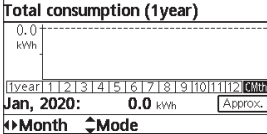
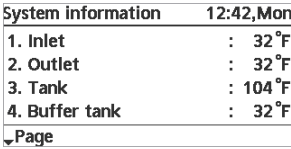
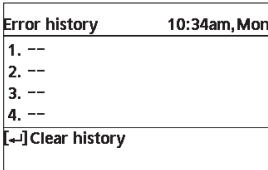
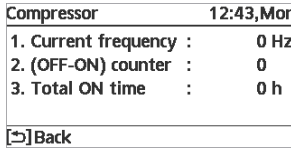
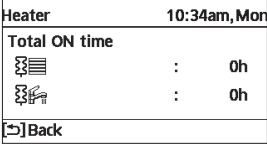
| Menu Function | | Description | Default Setting | Display |
|----------------|--|---|--|---|
| FUNCTION SETUP | Sterilization | <ul style="list-style-type: none"> To set the auto sterilization ON or OFF. Available only if connected to the tank. Do not use the system during sterilization in order to prevent scalding with hot water, or overheating of shower. Ask a qualified installer or service technician to determine the level of sterilization function field settings according to the local laws and regulations. | OFF |  |
| | Energy monitor | <ul style="list-style-type: none"> Present or historical chart of energy consumption, generation, or COP (Coefficient of Performance). For historical chart, the period is selected from 1 day/1 week/1year. Energy consumption (kWh) of heating, cooling, tank and total may be retrieved. The total power consumption is an estimated value based on 240 VAC and may differ from value measured by precise equipment. | <p>Present Select and retrieve</p> <p>Historical Chart Select and retrieve</p> |  |
| | System information | <ul style="list-style-type: none"> Shows all system information in each area. | <p>Actual system information of 10 items: Inlet / Outlet / Tank / Buffer tank / COMP frequency / Pump flow rate Select and retrieve</p> |  |
| | Error history | <ul style="list-style-type: none"> Refer to Troubleshooting for error codes. The most recent error code is displayed at the top. | Select and retrieve |  |
| | Compressor | <ul style="list-style-type: none"> Shows the compressor performance. | Select and retrieve |  |
| Heater | <ul style="list-style-type: none"> Total hours of ON time for Room heater/ Tank heater. | Select and retrieve |  | |

4 Location of Controls and Components

Table 4-1 Menu Functions continued

| Menu Function | Description | Default Setting | Display | |
|----------------|----------------------------|--|---------------------------------|--|
| PERSONAL SETUP | Touch sound | •Adjust the level of operation sound. | 3 | <p>Touch sound 12:00am, Mon Level 3 Select Confirm</p> |
| | LCD contrast | •Sets the screen contrast. | 3 | <p>LCD contrast 10:34am, Mon Low High Select Confirm</p> |
| | Backlight | •Sets the duration of screen backlight. | 1 min | <p>Backlight 10:34am, Mon OFF 5 mins 15 secs 10 mins 1 min Select Confirm</p> |
| | Backlight intensity | •Sets screen backlight brightness. | 4 | <p>Backlight intensity 10:34am, Mon Dark Bright Select Confirm</p> |
| | Clock format | •Sets the type of clock display. | 24h | <p>Clock format 10:34am, Mon 24h am/pm Select Confirm</p> |
| | Date & Time | •Sets the present date and time. | Year / Month / Day / Hour / Min | <p>Date & Time 10:34am, Mon Year/Month/Day Hour : Min 2020 / 01 / 07 10 : 00 am Select Confirm</p> |
| | Language | •Sets the display language for the top screen. | ENGLISH / FRANCAIS | <p>Language 12:36, Mon ENGLISH FRANCAIS Select Confirm</p> |
| | Unlock password | •4 digit password for all the settings. | 0000 | <p>Unlock password 10:34am, Mon 0000 Select Confirm</p> |

4 Location of Controls and Components

Table 4-1 Menu Functions continued

| Menu Function | Description | Default Setting | Display |
|--|--|-----------------|---------|
| INSTALLER SETUP > SYSTEM SETUP | Service Contact 1 / Contact 2 <ul style="list-style-type: none"> •Preset contact number for installer | OFF | |
| | Heater capacity <ul style="list-style-type: none"> •To reduce the heater power if unnecessary. | 6 kW | |
| | Anti-freezing <ul style="list-style-type: none"> •To activate or deactivate the water freeze prevention when the system is OFF | Yes | |
| | Tank connection <ul style="list-style-type: none"> •To connect tank to the system. | No | |
| | DHW capacity <ul style="list-style-type: none"> •To select tank heating capacity to variable or standard. Variable capacity heat up tank with fast mode and keep the tank temperature with efficient mode. •While standard capacity heat up tank with rated heating capacity. This option is available if Tank connection is selected (YES). | Variable | |
| | Buffer tank connection <ul style="list-style-type: none"> •To connect tank to the system and if selected YES, to set ΔT temperature. | No | |
| | | 9°F | |
| Tank heater <ul style="list-style-type: none"> •To select external or internal tank heater and if External is selected, set a timer for the heater to come on. This option is available if Tank connection is selected (YES). | Internal | | |
| | 0:20 | | |

4 Location of Controls and Components

Table 4-1 Menu Functions continued

| Menu Function | Description | Default Setting | Display | |
|--------------------------------|-----------------------------------|---|---------|--|
| INSTALLER SETUP > SYSTEM SETUP | Base pan heater | <ul style="list-style-type: none"> Type A - The base pan heater activates only during de-ice operation. Type B - The base pan heater activates when outdoor ambient temperature is 41°F or lower. | A | <div style="border: 1px solid black; padding: 5px;"> Base pan heater type 10:34am, Mon <div style="text-align: center;"> A ▼ B </div> Select [←] Confirm </div> |
| | Alternative outdoor sensor | <ul style="list-style-type: none"> To select an alternative outdoor sensor. | No | <div style="border: 1px solid black; padding: 5px; text-align: center;"> Yes ▲ No </div> |
| | Backup boiler | <ul style="list-style-type: none"> To select to enable or disable backup boiler. | No | <div style="border: 1px solid black; padding: 5px; text-align: center;"> Yes ▲ No </div> |
| | Circulation liquid | <ul style="list-style-type: none"> To select whether to circulate water or glycol mixture in the system. | Water | <div style="border: 1px solid black; padding: 5px;"> Circulation liquid 10:34am, Mon <div style="text-align: center;"> Water ▼ Glycol </div> Select [←] Confirm </div> |
| | Heat-Cool SW | | No | <div style="border: 1px solid black; padding: 5px; text-align: center;"> Yes ▲ No </div> |
| | Force heater | <ul style="list-style-type: none"> To turn on Force heater either manually (by default) or automatically. | Manual | <div style="border: 1px solid black; padding: 5px;"> Force heater 10:34am, Mon <div style="text-align: center;"> Auto ▲ Manual </div> Select [←] Confirm </div> |
| | Force defrost | <ul style="list-style-type: none"> If auto selection is set, the unit will start defrost operation if long heating hour operate during low outdoor temperature. | Manual | <div style="border: 1px solid black; padding: 5px; text-align: center;"> Auto ▲ Manual </div> |
| | Defrost signal | <ul style="list-style-type: none"> To turn on defrost signal to stop fan coil during defrost operation. If defrost signal set to Yes, Backup boiler function will not be available to use. | No | <div style="border: 1px solid black; padding: 5px; text-align: center;"> Yes ▲ No </div> |
| | Pump flow rate | <ul style="list-style-type: none"> To set variable flow pump control or fix pump duty control. | ΔT | <div style="border: 1px solid black; padding: 5px; text-align: center;"> ΔT ▼ Max. Duty </div> |

4 Location of Controls and Components

Table 4-1 Menu Functions continued

| Menu Function | Description | Default Setting | Display | |
|-----------------------------------|---|--|--|---|
| INSTALLER SETUP > OPERATION SETUP | Operation Setup <ul style="list-style-type: none"> To access to the four major functions or modes. | Heat / Cool/ Auto / Tank | <p>Operation setup 10:34am, Mon Heat Cool Auto Tank Select [↵] Confirm</p> | |
| | Heat <ul style="list-style-type: none"> To set various water & ambient temperatures for heating. | Water temp. for heating ON/ Outdoor temp. for heating OFF/ ΔT for heating ON / Heater ON/ OFF | | <p>Operation setup 10:34am, Mon Heat Water temp. for heating ON Outdoor temp. for heating OFF ΔT for heating ON Select [↵] Confirm</p> |
| | | Water temp. for heating ON Compensation curve Heating ON temps in compensation curve or direct input | | <p>Operation setup 10:34am, Mon Heat ON: Water temp. Compensation curve Direct Select [↵] Confirm</p> |
| | | Compensation Curve X axis: 23°F, 59°F Y axis: 131°F, 95°F Input the 4 temperature points (2 on horizontal X axis, 2 on vertical Y axis). | | <p>Heat ON: Water temp. 131°F 131 95°F 68 -4 23°F 59°F 59 Select [↵] Confirm</p> |
| | | <ul style="list-style-type: none"> Temperature range: X axis: -4°F ~ 59°F, Y axis: See below. Temperature range for the Y axis input: <ol style="list-style-type: none"> RAH040 model: 68°F ~ 149°F Regardless of the above setting, there is a limit to the water set temperature. | | |
| | | Water temp. for heating ON > Direct 95°F | | <p>Temperature for heating ON Operation setup 10:35am, Mon Heat ON: Water temp. Range: (68°F~149°F) Steps: ±1°F 95°F Select [↵] Confirm</p> |
| | | <ul style="list-style-type: none"> Min. ~ Max. range is conditional as follows: RAH040 model: 68°F ~ 149°F Regardless of the above setting, there is a limit to the water set temperature. | | |

4 Location of Controls and Components

Table 4-1 Menu Functions continued

| Menu Function | Description | Default Setting | Display | |
|-----------------------------------|--|--|--|--|
| INSTALLER SETUP > OPERATION SETUP | <ul style="list-style-type: none"> To set various water & ambient temperatures for heating. | Outdoor temp. for heating OFF 75°F | Temperature for heating OFF Operation setup 12:50, Mon Heat OFF: Outdoor temp. Range: (41°F~95°F) Steps: ±1°F 75 °F Select Confirm | |
| | | ΔT for heating ON 9°F Set ΔT for heating ON. * This setting will not be available to set when pump flow rate set to Max. duty. | Operation setup 12:51, Mon Heat ON: ΔT Range: (2°F~27°F) Steps: ±1°F 9 °F Select Confirm | |
| | | Heater ON/OFF | | |
| | | Heater ON/OFF> Outdoor temp. for heater ON 32°F Temperature for heater ON | Operation setup 12:51, Mon Heater ON: Outdoor temp. Range: (-4°F~59°F) Steps: ±1°F 32 °F Select Confirm | |
| | | Heater ON/OFF> Delay time for heater ON 0:30 min Delay time for heater to turn on | Operation setup 10:34am, Mon Heater ON: Delay time Range: (0:10~1:00) Steps: ±0:10 0:30 Select Confirm | |
| | | Heater ON/OFF> Water temperature for heater ON -7°F Setting of water temperature to turn on from water set temperature. | Operation setup 12:53, Mon Heater ON: ΔT of target Temp. Range: (-18°F~-4°F) Steps: ±1°F -7 °F Select Confirm | |
| | | Heater ON/OFF> Water temperature for heater OFF -4°F Setting of water temperature to turn off from water set temperature. | Operation setup 12:53, Mon Heater OFF: ΔT of target Temp. Range: (-6°F~0°F) Steps: ±1°F -4 °F Select Confirm | |



4 Location of Controls and Components

Table 4-1 Menu Functions continued

| Menu Function | Description | Default Setting | Display |
|-----------------------------------|--|--|---------|
| INSTALLER SETUP > OPERATION SETUP | <ul style="list-style-type: none"> To set various water & ambient temperatures for cooling. | Water temperatures for cooling ON and ΔT for cooling ON. | |
| | | Water temp. for cooling ON Cooling ON temperatures in compensation curve or direct input. | |
| | | Water temp. for cooling ON > Compensation Curve X axis: 68°F, 86°F Y axis: 59°F, 50°F Input the 4 temperature points (2 on horizontal X axis, 2 on vertical Y axis) | |
| | | Water temp. for cooling ON > Direct 50°F Set temperature for Cooling ON | |
| | | ΔT for cooling ON 9°F Set ΔT for cooling ON * This setting will not be available to set when pump flowrate set to Max. duty. | |

4 Location of Controls and Components

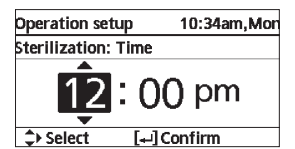
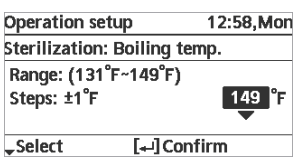
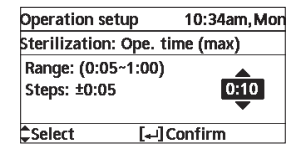
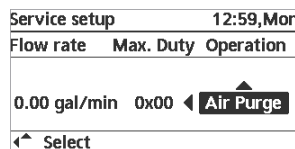
Table 4-1 Menu Functions continued

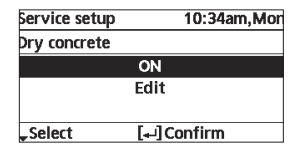
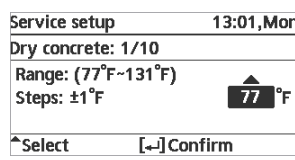
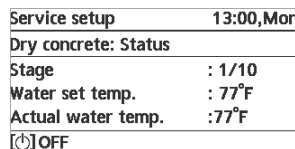
| Menu Function | | Description | Default Setting | Display |
|-----------------------------------|--------------------|---|--|---|
| INSTALLER SETUP > OPERATION SETUP | Tank | <ul style="list-style-type: none"> Automatic switch from Heat to Cool or Cool to Heat. | Sterilization: Time 12:00 Time of the selected day(s) of the week to sterilize the tank 0:00 ~ 23:59 |  |
| | | | Sterilization: Boiling Temp 149°F Set boiling temperatures for sterilize the tank. |  |
| | | | Sterilization: Ope. time (max) 0:10 Set sterilizing time (in hours and minutes) |  |
| INSTALLER SETUP > SERVICE SETUP | Pump maximum speed | <ul style="list-style-type: none"> To set the maximum speed of the pump. | Setting the flow rate, max. duty and operation ON/OFF of the pump. Flow rate: XX:X gal/min Max. Duty: 0x40 ~ 0xFE, Pump: ON/OFF/Air Purge |  |
| | Pump down | <ul style="list-style-type: none"> To set the pump down operation. | Pump down operation ON |  |
| | Dry Concrete | <ul style="list-style-type: none"> To dry the concrete (floor, walls, etc.) during construction. Do not use this menu for any other purposes and in period other than during construction | Edit to set the temperature of dry concrete. ON / Edit |  |
| | | | Edit Stages: 1 Temperature: 77°F Heating temperature for drying the concrete. Select the desired stages: 1 ~ 10, range: 1 ~ 99 |  |
| | | | ON Confirm the setting temperatures of dry concrete for each stage. |  |

4 Location of Controls and Components

Table 4-1 Menu Functions continued

| Menu Function | Description | Default Setting | Display |
|---------------------------------|--|---|---------|
| INSTALLER SETUP > SERVICE SETUP | <ul style="list-style-type: none"> To set up to 2 contact names and numbers for the User. | Service engineer's name and contact number. Contact 1 / Contact 2 | |
| | | Contact 1 / Contact 2 Contact name or number. Name / phone icon | |
| | | Input name and number Contact name: alphabet a ~ Z. Contact number: 1 ~ 9 | |

5 Diagrams

Figure 5-1 Optional Piping System

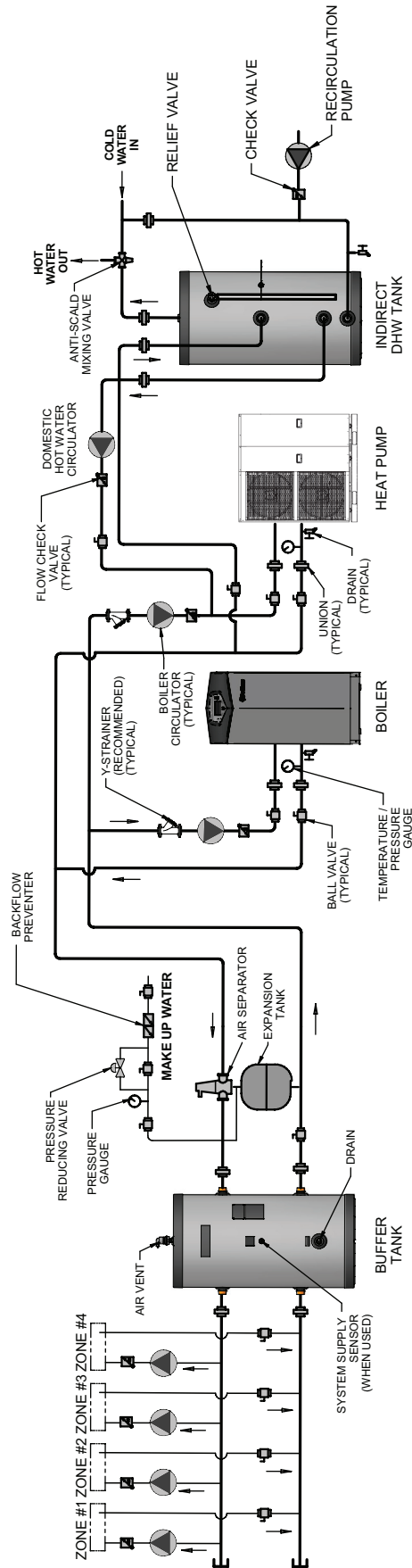

6 Installation

Handling of the Mono bloc unit

The Mono bloc unit is a large and heavy unit. The handling of the unit is only to be done by lifting tools with slings. These slings can be fitted into sleeves at the unit's base frame.

Select the best location

Install the Mono bloc unit in outdoor locations only. Avoid installations in areas where the ambient temperature may drop below -4°F. The Mono bloc unit must be installed on a flat, solid surface. The installation place must be removed from any heat source or steam which may effect the operation of the Mono bloc unit.

The Mono bloc unit must be installed:

- In a place where air circulation is good.
- In a place where drainage can be easily done.
- In a place where Mono bloc unit's operation noise will not cause discomfort to the user.
- In a place which is accessible for maintenance.
- In a place where flammable gas leaking might not occur.
- In a place where the Mono bloc unit's piping and wiring lengths come within reasonable ranges.

Be sure to keep minimum distance of spaces as illustrated in Figure 9-1, from the wall, ceiling, or other obstacles.

If an awning is built over the unit to prevent direct sunlight or rain, be careful that heat radiation from the condenser is not obstructed. Do not place any obstacles which may cause a short circuit of the discharged air. Avoid installing the Mono bloc unit at a location where the suction side may be exposed directly to wind.

If the Mono bloc unit installed near the sea, a region with high content of sulphur, or an oily location (e.g. machinery oil, etc.), its lifespan may be shortened.

When installing the product in a place where it will be affected by typhoon or strong wind such as wind blowing between buildings, including the rooftop of a building and a place where there is no building in surroundings, fix the product with an overturn prevention wire, etc.

Mono bloc unit installation

Mono bloc unit will become heavy when filled with water. Please install the unit on a strong concrete floor and consider the weight of the unit and water. Fix Mono bloc unit on the concrete floor with 7/16" - 20 UNF anchor bolt at 4 locations. The pull-out strength of these anchor bolts must be above 3372 lbf (15000N).

Figure 6-1 Grip anchor vs Embedded anchor

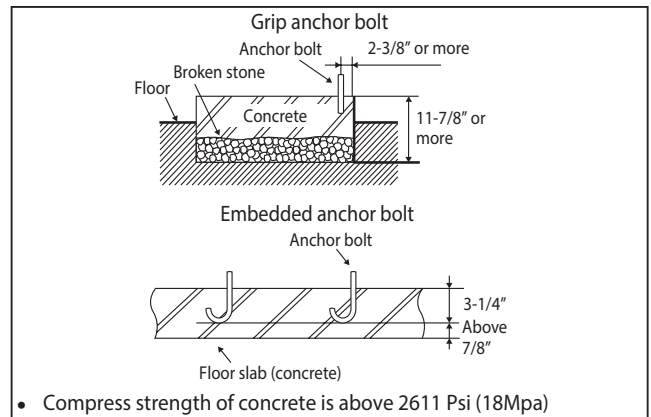

Disposal of Mono block unit drain water

When a Drain elbow is used, please ensure to follow below:

- The unit should be placed on a stand which is taller than 2 inches.
- Cover the 8 holes (ø7/8 inches) with Rubber cap (refer to illustration below)
- Use a tray (field supply) when necessary to dispose the Mono bloc unit drain water.

If the unit is used in an area where the temperature falls below 32°F for 2 or 3 consecutive days, it is recommended not to use the Drain elbow and Rubber cap. If used, the drain water freezes and the fan will not rotate.

Figure 6-2 Unit drain

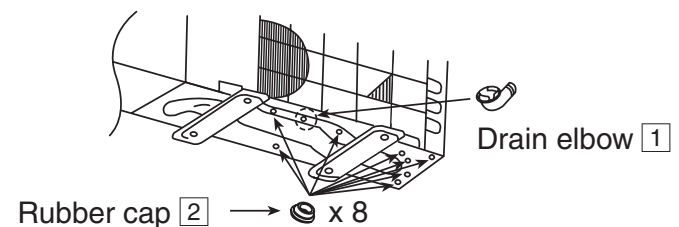

Table 6-1 Attached Accessories

| No. | Accessories Part | Qty. |
|-----|--------------------|------|
| 1 | Drain elbow | 1 |
| 2 | Rubber cap | 8 |
| 3 | Remote controller | 1 |
| 4 | Outdoor sensor | 1 |
| 5 | Tank sensor | 1 |
| 6 | Buffer tank sensor | 1 |

6 Installation

Table 6-2 Field Supplied Accessories (Optional)

| No. | Part | Specification |
|-----|-----------------|-------------------------|
| i | two-way valve | 20 - 30VAC, 0.5A |
| ii | three-way valve | 20 - 30VAC, 0.5A |
| iii | Room thermostat | 20 - 30VAC, 2VA (0.15A) |
| v | Extra pump | 110-130VAC, 0.54A |

Figure 6-3 Minimum distance for installation

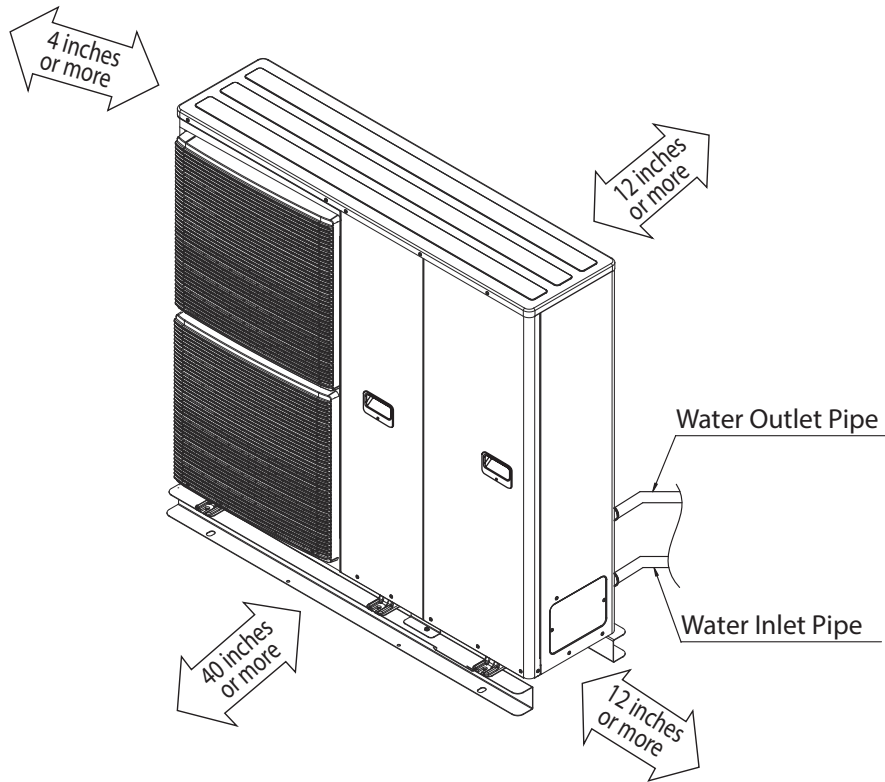

6 Installation

Piping installation

WARNING This section is for authorized and licensed electrician / water system installers only. Work behind the cabinet front plate secured by screws must only be carried out under supervision of qualified installer or service technician.

Typical Piping Installation

A qualified installer or service technician should install this water circuit.

This water circuit must comply with relevant national regulations, and local building regulation codes. Ensure the components installed in the water circuit could withstand water pressure during operation. Do not apply excessive force to piping that may damage the pipes. Use Rp 1 1/4" nut for both water inlet and water outlet connection and clean all piping with tap water before connecting to the Mono bloc unit. Cover the pipe end to prevent dirt and dust when inserting it through a wall. If an existing tank is to be connected to this Mono bloc unit, ensure the pipes are clean before water pipe installation is carried out.

Choose proper sealer which can withstand the pressures and temperatures of the system. Make sure to use two spanners to tighten the connection. Tighten the nuts with torque wrench: 86.74 lb*ft. If non-brass metallic piping is used for installation, make sure to insulate the piping to prevent galvanic corrosion. Do not use pipes that are crushed or deformed. If these inferior pipes are used, it may cause unit malfunction. Make sure to insulate the water circuit piping (insulator thickness: 3/4 inches or more) to prevent condensation during cooling operation and reduction of heating capacity, as well as avoid freezing of the outdoor water circuit piping during winter season.

After installation, check the water leakage condition in connection area during test run. In case of a power supply failure or pump operating failure, drain the system. When water is idle inside the system, it is likely to freeze which could damage the system. See Figure 9-4 for example illustration.

Figure 6-4 Unit drainage in case of power outage

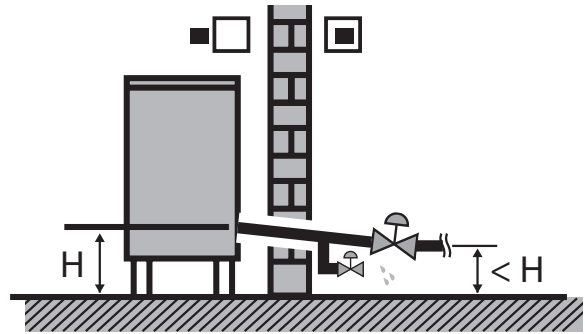

Drainage Piping Installation

Use a drain hose with an inner diameter of 5/8 inches. The hose must be installed in a continuously downward direction and left open to the frost-free atmosphere.

If the drain hose is long, use a metal support fixture along the way to eliminate the wavy pattern of the drain tube. Water will drip from this hose, therefore the outlet of this hose must be installed in an area where the outlet cannot become blocked.

Do not insert this hose into a sewage or drain pipe that may generate ammonia gas, sulfuric gas, etc. If necessary, use a hose clamp to tighten the hose at the drain hose connector to prevent it from leaking.

CAUTION Do not over tighten. This can cause water leakage.

Figure 6-5 Drain hose connector

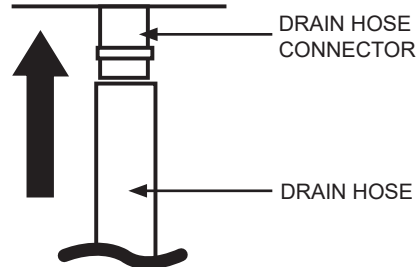

6 Installation

WARNING This section is for authorised and licensed electricians only. Work behind the cabinet front plate secured by screws must only be carried out under supervision of qualified installer or service technician.

Remove the cabinet front plate

1. Remove the four (4) mounting screws as shown in the illustration.
2. Slide the cabinet front plate downward to release the pawls. Then, pull it toward front to remove it.

Figure 6-6 Removing the cabinet front plate

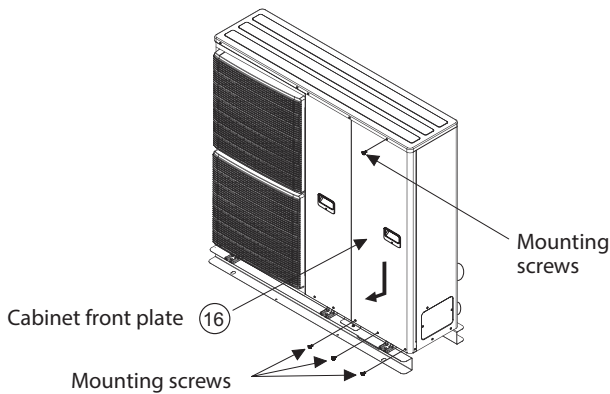

Fixing of power supply cord

1. An isolating device must be connected to the power supply cable.
2. The isolating device (disconnecting means) should have minimum 1/8 inch contact gap.
 - Connect the approved polychloroprene sheathed power supply 1 cord and power supply 2 cord and type designation 60245 IEC 57 or heavier cord to the terminal board, and to the other end of the cord to isolating device (Disconnecting means). See table 9-3 for cable size requirement.
 - To avoid the cable and cord being damaged by sharp edges, the cable and cord must be passed through the designated holes before being connected to the terminal block.
3. Secure the cable onto the control board with the holder (clammer).

Table 6-3 Cable size requirements

| Model | Cable Size | Isolating Devices | Recommended RCD |
|--------|-----------------|-------------------|------------------|
| RAH040 | 3 x min. 10 AWG | 30A | 30mA, 2P, type A |

Figure 6-7 Unit terminal

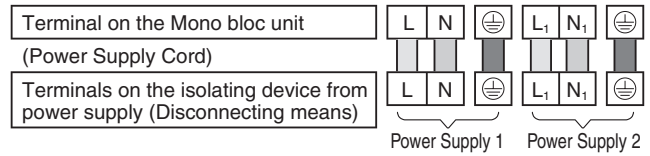
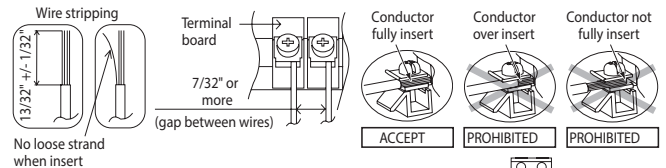
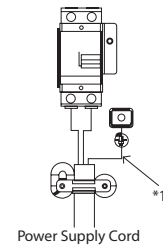

Figure 6-8 Wire stripping and connecting requirement



| Terminal screw | Tightening torque lb*ft |
|----------------|-------------------------|
| 8-32 UNC | 1.158 ~ 1.446 |
| 10-24 UNC | 1.446 ~ 1.807 |

*1 - Earth wire must be longer than other cables for safety reasons.



Connection requirement for RAH040

This equipment's Power Supply 1 complies with IEC 61000-3-12 provided that the short circuit power S_{sc} is greater than or equal to 1900kW at the interface point between the user's supply and the public system. It is the responsibility of the installer or user of the equipment to ensure, by consultation with the distribution network operator if necessary, that the equipment is connected only to a supply with a short circuit power S_{sc} greater than or equal to 1900kW.

The equipment's Power Supply 1 complies with IEC 61000-3-11 and shall be connected to a suitable supply network, having services current capacity $\geq 100A$ per phase. Please confirm with the local power provider that the service current capacity at the interface point is sufficient for the installation of the equipment.

This equipment's Power Supply 2 complies with IEC 61000-3-12. The equipment's Power Supply 2 complies with IEC 61000-3-11 and shall be connected to suitable supply network, with the following maximum permissible system impedance $Z_{max} = 0.193 \text{ ohm } (\Omega)$ at the interface.

Please confirm with local power provider to ensure that the Power Supply 2 is connected only to a supply whose impedance is less than the units rated value.

6 Installation

Connection requirement for RAH040

All connections shall follow the local national wiring standard. It is strongly recommended to use manufacturer-recommended parts and accessories for installation.

For connection to main PCB:

1. Two-way valve connection is 20-30VAC, with a 0.5A maximum. Wires shall be a minimum 16AWG with type designation 60245 IEC 57 or heavier, or similarly double insulation sheathed cable.
2. Three-way valve connection is 20-30VAC, with a 0.5A maximum. Wires shall be a minimum 16AWG, with type designation 60245 IEC 57 or heavier, or similarly double insulation sheathed cable.
3. Room Thermostat connection is 20-30VAC, with a 0.15A maximum. Wires shall be a minimum 22AWG, with type designation 60245 IEC 57 or heavier cord, or similarly double insulation sheathed cable.
4. Maximum output power of booster heater shall be ≤ 3 kW. Booster heater connection is 208-240VAC, with a 13A maximum. Wires shall be a minimum 12AWG, with type designation 60245 IEC 57 or heavier.
5. Extra pump connection is 110-130VAC, with a 0.54A maximum. Wires shall be a minimum 16AWG, with type designation 60245 IEC 57 or heavier.
6. Boiler contact/Defrost signal connection is 120/240VAC, with a 3A maximum. Wires shall be a minimum 16AWG, with type designation 60245 IEC 57 or heavier.
7. Heat/Cool switch connection is 24VDC, with a 0.2A maximum. Wires shall be a minimum 18AWG, double insulation layer of PVC-sheathed or rubber-sheathed cable.
8. Tank sensor connection is 5VDC, with a 0.2mA maximum. Wires shall be a minimum 22AWG, double insulation layer (with insulation strength of min 30V) of PVC-sheathed or rubber-sheathed cable.
9. Buffer tank sensor connection is 5VDC, with a 0.2mA maximum. Wires shall be a minimum 22AWG, double insulation layer (with insulation strength of min 30V) of PVC-sheathed or rubber-sheathed cable.
10. Outdoor air sensor connection is 5VDC, with a 0.2mA maximum. Wires shall be a minimum 22AWG, double insulation layer of PVC-sheathed or rubbersheathed.
11. OLP booster heater connection is 12VDC, with a 0.2A maximum. Wires shall be a minimum 16AWG, double insulation layer of PVC-sheathed or rubber-sheathed cable.

Figure 6-9 Cable and cord connections

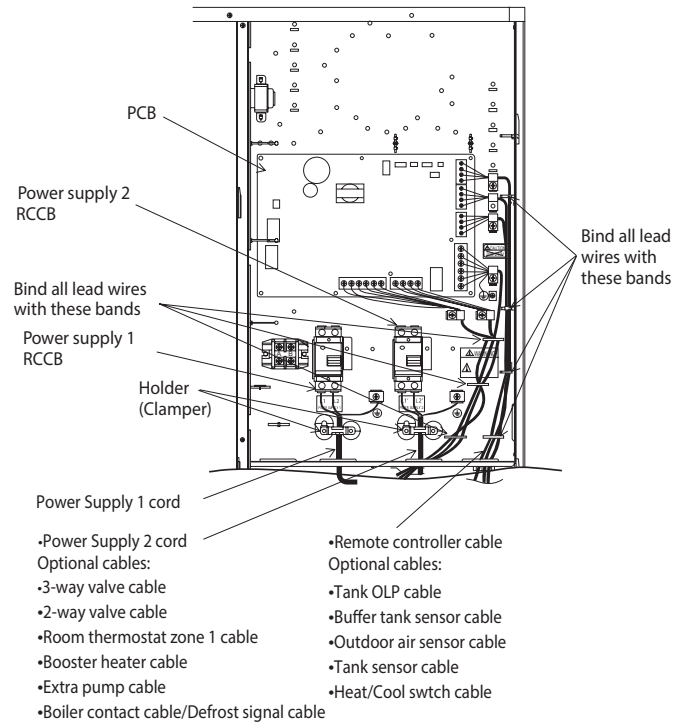

Table 6-4 Screw terminal tightening torque

| Terminal screw on PCB | Maximum tightening torque lb*ft |
|-----------------------|---------------------------------|
| 4-40 UNC | 0.3688 |
| 8-32 UNC | 0.8851 |

Installation of Remote Controller

Installation location

Install at the height of 3-1/4 to 5 feet from the floor at a location where average room temperature can be detected). Install vertically against the wall.

Avoid the following locations for installation.

1. By the window, etc. exposed to direct sunlight or direct air.
2. In the shadow or backside of objects deviated from the room airflow.
3. Location where condensation occurs (The Remote Controller is not moisture proof or drip proof.)
4. Location near a heat source.
5. Uneven surface.

Keep distance of 3-1/4 feet or more from the TV, radio and PC (due to fuzzy image or noise).

6 Installation

Remote controller wiring

Remote controller connection is 16VDC, with a 25mA maximum. Wires shall be a minimum 22AWG, of double insulation PVC-sheathed or rubber sheathed cable. Total cable length shall be 164 feet or less. Be careful not to connect cables to other terminals (e.g. power source wiring terminal). Malfunction may occur. Do not bundle together with the power source wiring or store in the same metal tube. Operation error may occur.

Figure 6-10 Terminal for remote control wiring

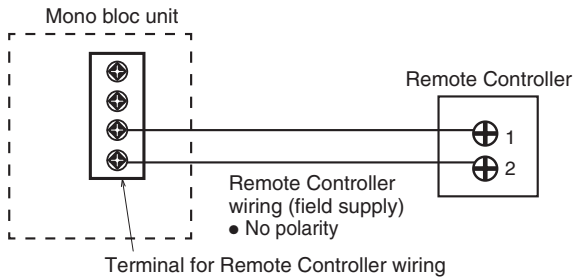

Mounting the remote controller

For the exposed type, use a drill to make two holes for the mounting screws.

Figure 6-11 Removing top case from remote controller

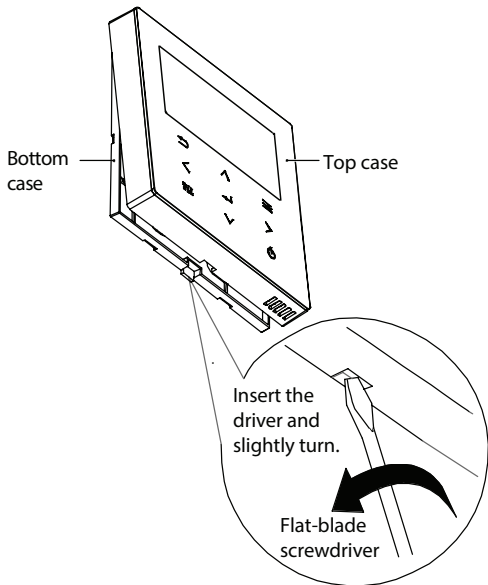

WARNING This section is for authorized and licensed electrician only. Work behind the Cabinet Front Plate secured by screws must only be carried out under supervision of qualified contractor, installation engineer or service person.

Figure 6-12 Mounting instructions - exposed

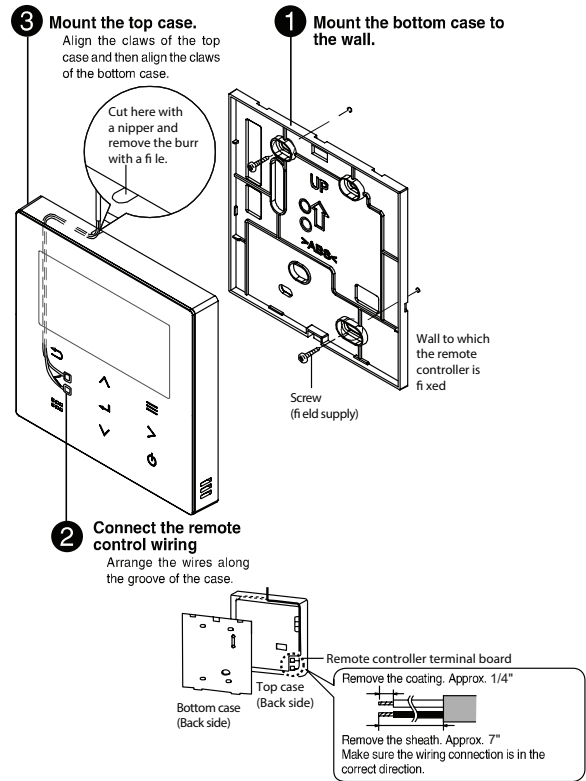

For the embedded type, use a drill to make two holes for the mounting screws.

Figure 6-13 Mounting instructions - embedded

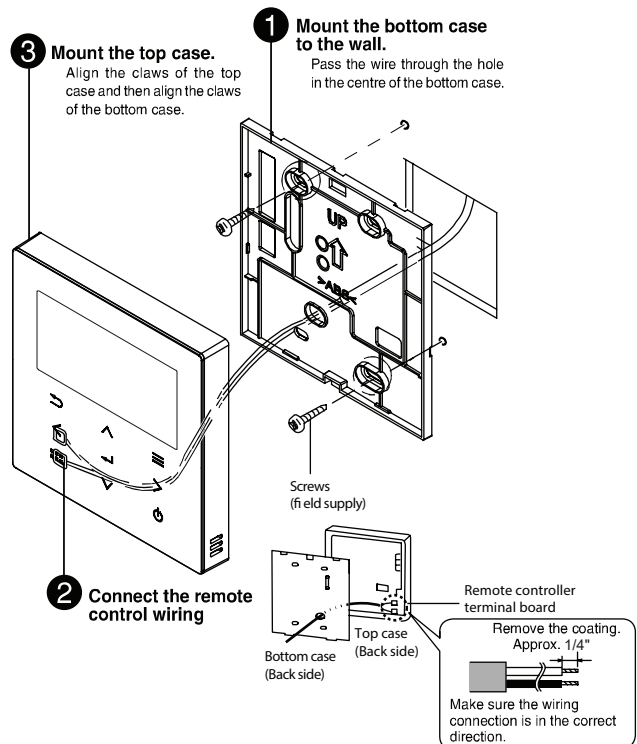

6 Installation

Charging the water

Make sure all the piping installations are properly done before carrying out the following steps:

1. Open Cabinet front plate to access to the Pressure Relief Valve and Air Purge Valve.
2. Turn the plug on the Air Purge Valve outlet counterclockwise by one complete turn from fully closed position.

Figure 6-14 Turn plug counter clockwise

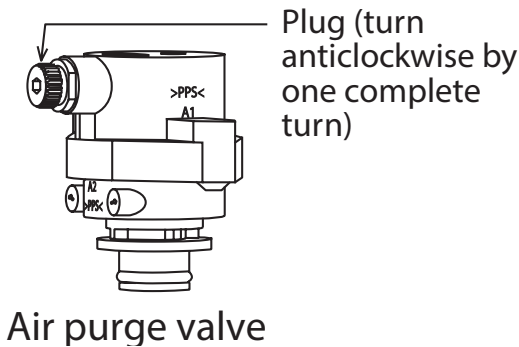

3. Set the Pressure Relief Valve level “DOWN”.

Figure 6-15 Pressure relief valve

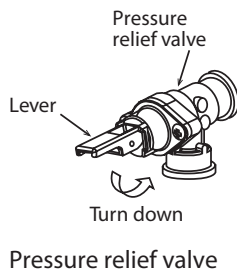

4. Start filling water (with pressure more than 15 Psi) to the Mono bloc unit via water inlet. Stop filling water if the free water flow through Pressure Relief Valve drain hose.
5. Turn ON the power supply and make sure Water Pump is running.
6. Check and make sure no water leaking at the tube connecting points.
7. Reinstall the Cabinet front plate by tightening the 2 mounting screws.

Reconfirmation



WARNING Be sure to switch off all power supply before performing each of the processes in this section. Before obtaining access to terminals, all supply circuits must be disconnected.

Check Water Pressure

Water pressure should not be lower than 7 Psi (with inspects the Water Pressure Gauge). If necessary add tap water into the water circuit.

Check Pressure Relief Valve

1. Check for correct operation of Pressure Relief Valve by turning on the lever to become horizontal.
2. If you do not hear a clacking sound (due to water drainage), contact your local a qualified installer or technician.
3. Push down the lever after finish checking.
4. In the case water keeps draining out from the unit, switch off the system, and then contact your local a qualified installer or technician.

Expansion Vessel Pre Pressure Checking

1. The Mono bloc unit has a build-in Expansion Vessel with 2.64 Gallons air capacity and initial pressure of 15 Psi.
2. Without an antifreeze agent, the total amount of water in the system should be below 52.83 Gallons.
3. If the total amount of water is more than 52.83 Gallons, please add an expansion vessel (field supply).
4. In the case of using an antifreeze agent, the expansion rate ϵ is different depending on its maker.
5. Please refer to the antifreeze agent maker for the expansion rate ϵ before calculating the upper limit water volume of the system.
6. The expansion vessel capacity required for the system can be calculated from the formula below.

$$V = \frac{\epsilon \times V_0}{(P_0/P_1) - (P_0/P_2)}$$

V : Required gas volume <expansion vessel volume Gallons>

V_0 : System total water volume <Gallons>

ϵ : Expansion rate

P_1 : Starting system pressure (PSI)

P_2 : Final system pressure (PSI)

P_0 : Initial pressure (PSI)

- It's advised to add 10% margin for required volume of calculation.

If the height difference between the Mono bloc unit and the highest point of the system water circuit (H) is more than 23 feet, please adjust the initial pressure of the expansion vessel (P_0) according to the following formula.

$$P_0 = (1.45 \times H + 4.35) \text{ PSI}$$

Check RCCB

Ensure the RCCB set to “ON” before checking RCCB. Turn on the power supply to the Mono bloc unit. This testing can only be done when power is supplied to the Mono bloc unit.

6 Installation

WARNING Be careful not to touch parts other than RCCB test button when the power is supplied to Mono bloc unit. Touching the Mono bloc unit while powered could result in electrical shock.

Push the “TEST” button on the RCCB. The lever will turn down and indicate “0”, if it is functioning normally. Contact authorized installer or technician if the RCCB malfunctions.

Turn off the power supply to the Mono bloc unit.

If the RCCB functions normally, set the lever to “ON” again after testing is complete.

This product contains fluorinated greenhouse gasses. Refrigerant type : R32 (GWP=675) for RAH040 Amount : 3.53 lbs (1.080 ton CO2 equivalent)

Test Run

- Before test run, make sure below items have been checked:
 - Pipe work is properly done.
 - Electric cable connections are properly done.
 - Mono bloc unit is filled up with water and trapped air is released.
- Antifreeze agent must be added into the water circuit to prevent freezing of water when outdoor ambient temperatures are low.
 - Recommended antifreeze: Propylene glycol: 40% (equivalent to -4°F)
- Turn ON the Mono bloc unit and RCCB.

NOTICE During winter, turn on the power supply and standby the unit for at least 15 minutes before test run. Allow sufficient time to warm up refrigerant and prevent wrong error code judgement.

- For normal operation, Water Pressure Gauge reading should be between 7 Psi and 43.5 Psi.
- After test run, clean the Magnetic Water Filter Set. Reinstall it after cleaning.

Air Purge Valve Test Run

Before test running the water circulation circuit, loosen the plug on the air purge valve on the unit counterclockwise and be sure to thoroughly release any air from the drain plugs on each terminal.

During air purging, keep water pressure applied to the circulation circuit by supplying water to the circuit. (If the water pressure drops, the air cannot be discharged sufficiently.) Particularly, when the three-way valve switches from the heating circuit to the tank circuit five minutes after the air purge operation begins, the air that has accumulated in the heat exchanger inside the tank may flow into the pump, causing it to dry run. In this case, please quickly remove the air from the circulation circuit by releasing the air from the drains located at the back of the mono bloc unit.

Figure 6-16 Air purge valve

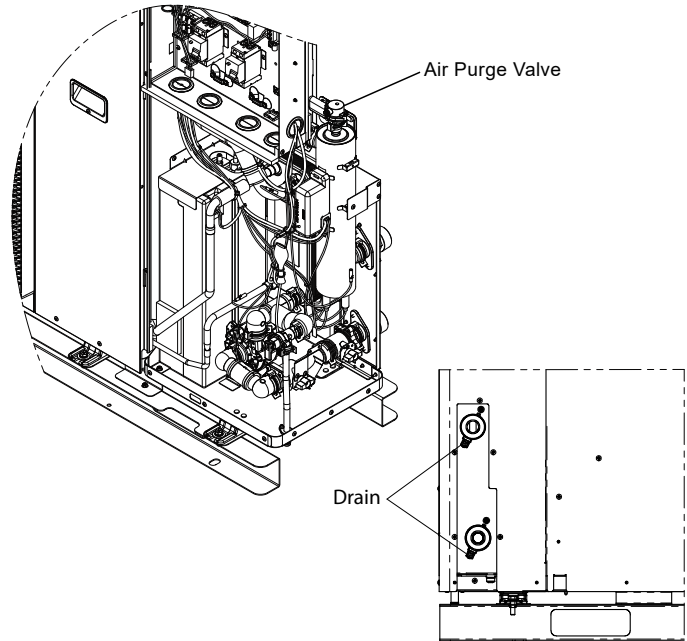
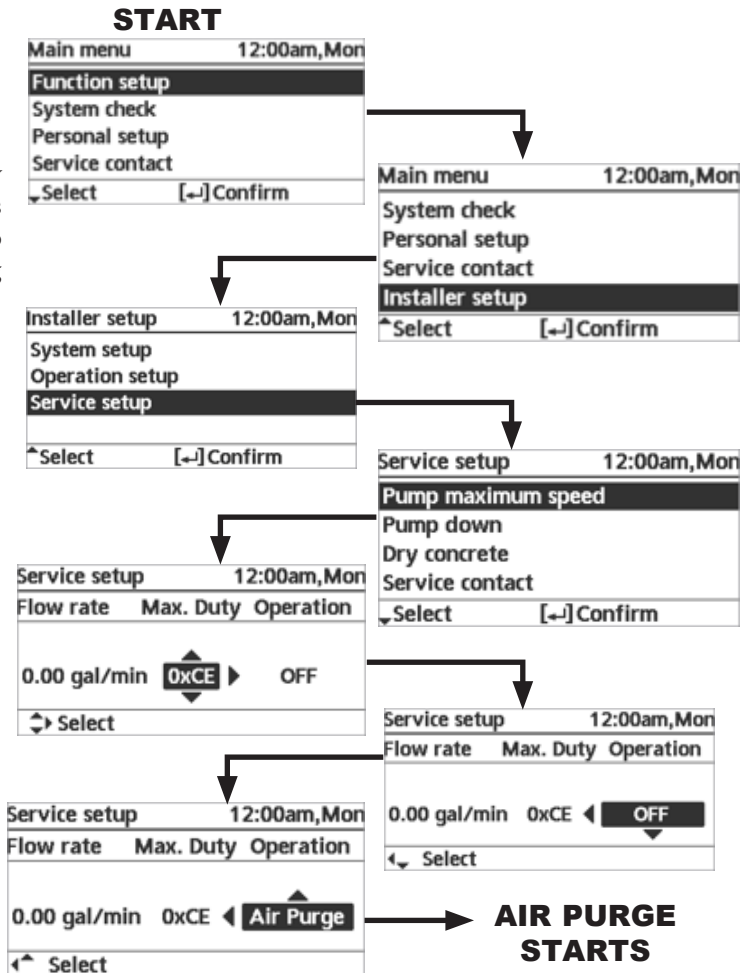

Figure 6-17 Air purge valve screens - step by step



6 Installation

NOTICE

If the pump is left running dry for a long period of time, it may cause the pump to malfunction.

Once all the air has been removed from the water circulation circuit, such as when the flow rate remains constant for a certain period of time, turn it OFF and press Menu to end the air purge. After the air purge operation, carry out normal operation, and when you can no longer hear the sound of air flowing from the water circulation circuit, turn the air purge valve plug clockwise to tighten it.

Check water flow or water circuit

Confirm the maximum water flow during main pump operation is no less than 3.96 GPM. Water flow can be checked through service setup. Heating operation at low water temperature with lower water flow may trigger “H75” during defrost process.

Reset overload protector

Overload Protector prevents the water from over heating. When the Overload Protector trips at high water temperature, take the following steps to reset it:

1. Take out the cover.
2. Use a test pen to push the center of the button gently in order to reset the Overload Protector.
3. Fix the cover to its original position.

Figure 6-16 Overload protector

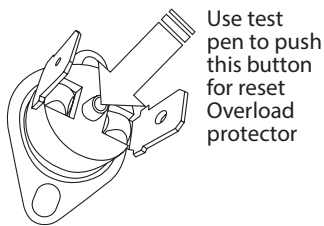

Variation of system

This section introduces variation of various systems using Air-To-Water Heatpump and actual setting method.

Temperature setting variation for heating

Remote Controller

Connect floor heating or radiator directly to the Mono bloc. This is the basic form of the most simple system.

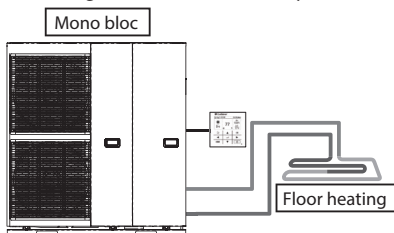

Setting of remote controller

Installer setting
System setup

Zone & Sensor:
Water temperature

Maintenance

In order to ensure optimal performance of the unit, seasonal inspections on the unit, functional check of RCCB, field wiring, and piping have to be carried out at regular intervals. This maintenance should be carried out by a qualified installer or service technician.

Maintenance for magnetic water filter set

1. Remove the cover by loosening the mounting screws to access to the Magnetic Water Filter Set.
2. Turn OFF power supply.
3. Set the two valves for the Magnetic Water Filter Set to “CLOSE”.
4. Take off the clip, then gently pull out the mesh. A small amount of water may drain out from it.
5. Clean the mesh with warm water to remove all stains. Use a soft brush if necessary.
6. Reinstall the mesh to the Magnetic Water Filter Set and clip it back on.
7. Set the two valves for the Magnetic Water Filter Set to “OPEN”.
8. Turn ON power supply.
9. After cleaning, reinstall the cover by tightening the mounting screws properly.

Figure 6-17 Remove/ reinstall cover

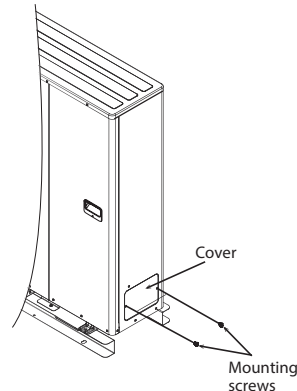

6 Installation

Room Thermostat

Connect floor heating or radiator directly to the Mono bloc. Install the remote controller in the room where floor heating is installed. This is an application that uses remote controller as Room Thermostat.

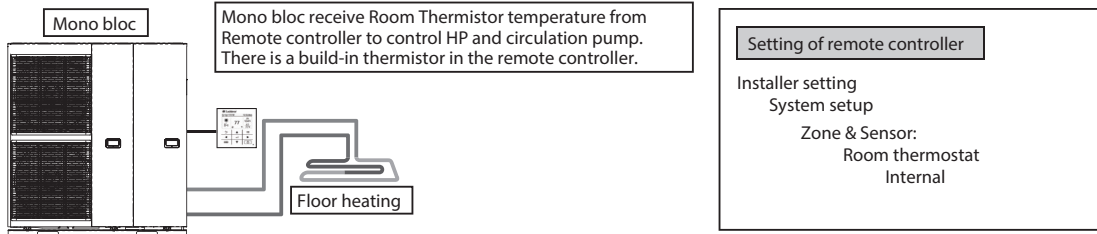

External Room Thermostat

Connect floor heating or radiator directly to Mono bloc. Install separate external Room Thermostat (field supply) in the room where floor heating is installed. This is an application that uses external Room Thermostat.

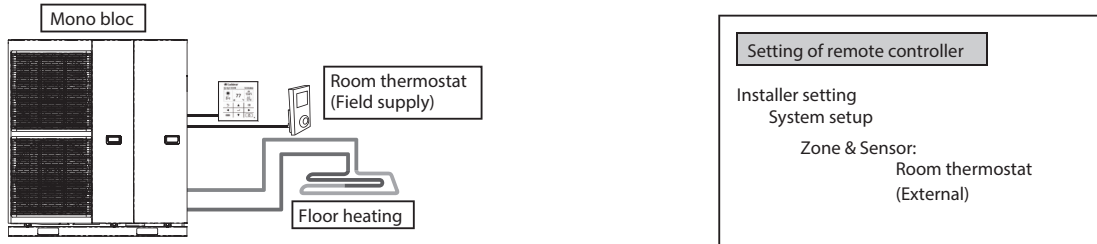

Installation Examples - Systems with Optional Equipment

DHW (Domestic Hot Water) tank connection

This is an application that connects the DHW tank to the Mono bloc through three-way valve.

DHW tank's temperature is detected by tank thermistor (specified by the manufacturer).

Figure 6-18 DHW Tank System Connection

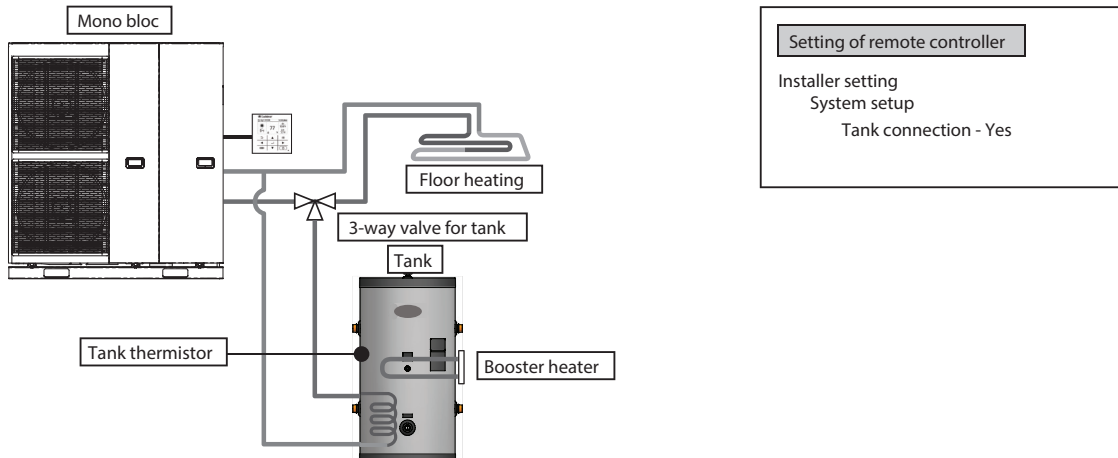

6 Installation

Buffer tank connection

This is an application that connects the buffer tank to the Mono bloc. Buffer tank's temperature is detected by buffer tank thermistor (specified by the manufacturer).

Figure 6-19 Buffer Tank system connection

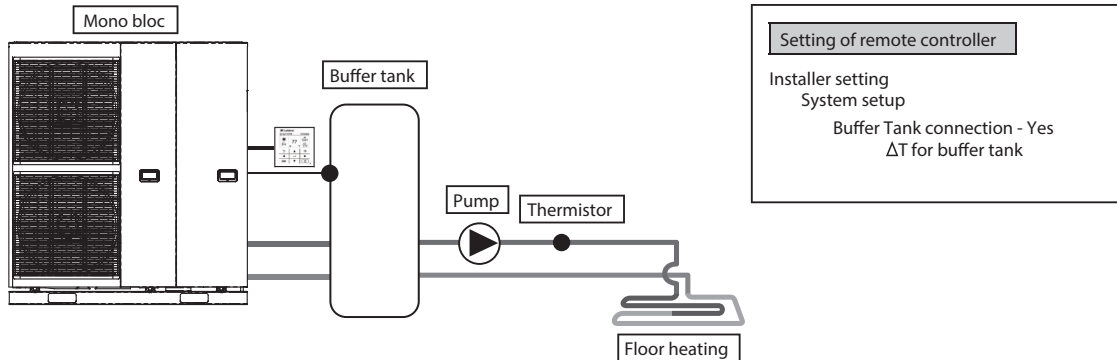

Boiler connection

This is an application that connects the boiler to the Mono bloc, to compensate for insufficient capacity by operate boiler when outdoor temperature drops & heat pump capacity is insufficient.

Boiler is connected parallel with heat pump against heating circuit. There are 3 modes selectable by remote controller for boiler connection. Besides that, an application that connects to the DHW tank's circuit to heat up tank's hot water is also possible.

(Operation setting of boiler shall be responsible by installer.)

Depending on the settings of the boiler, it is recommended to install buffer tank as temperature of circulating water may get higher. (It must connect to buffer tank especially when selecting Advanced Parallel setting.)

Figure 6-20 Boiler system connection

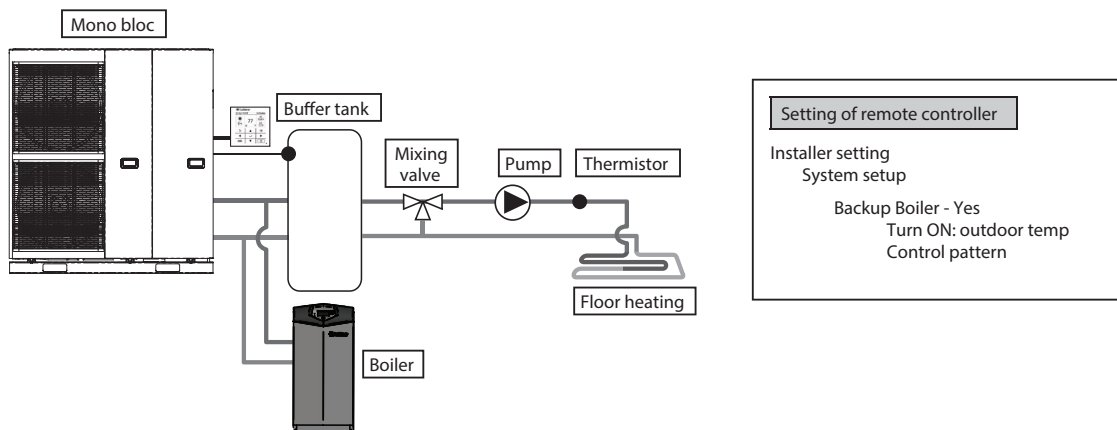

CAUTION Make sure the boiler and its integration in the system complies with applicable legislation. Make sure the return water temperature from the heating circuit to the Mono bloc does NOT exceed 131°F. Boiler is turned off by safety control when the water temperature of the heating circuit exceed 185°F.

WARNING Lochinvar is NOT responsible for incorrect or unsafe installations of the boiler system.

6 Installation

Fixing external devices

Length of Connecting Cables

When connecting cables between Mono bloc and external devices, the length of the said cables must not exceed the maximum length as shown in the following table.

Table 6-5 Cable length requirements

| External Device | Maximum cable length (ft) |
|---------------------------------|---------------------------|
| Two-way valve | 164 |
| Three-way valve | 164 |
| Room thermostat | 164 |
| Booster heater | 164 |
| Extra pump | 164 |
| Boiler contact / Defrost signal | 164 |
| Tank sensor | 98 |
| Outdoor air sensor | 98 |
| Tank OLP | 98 |
| Buffer tank sensor | 98 |
| Heat/Cool switch | 98 |

Figure 6-21 Main PCB connections

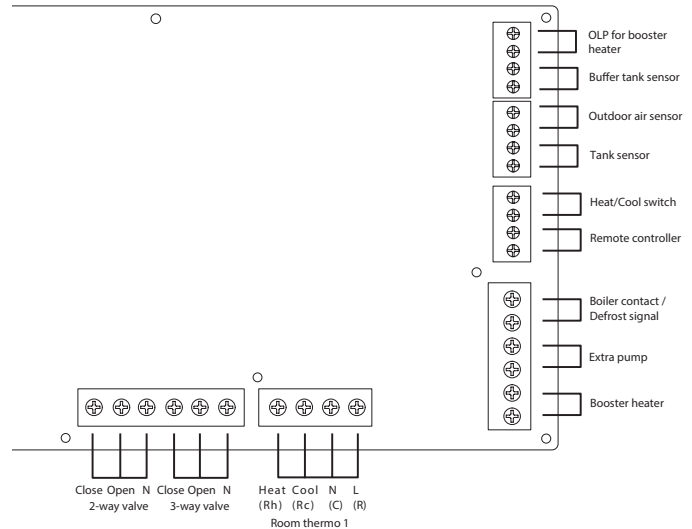

Table 6-6 PCB Connections

| Signal Inputs | Room Thermostat 1 | L N = 24VAC, Heat, Cool=Enable Dry Contact Terminals |
|-------------------|---------------------------------|---|
| | OLP for booster heater | Dry contact Vcc-Bit1, Vcc-Bit2 open/short (System setup necessary) It is connected to the safety device (OLP) of DHW tank. |
| | Remote controller | 16VDC (Please use 2 cores wire for relocation and extension). |
| Outputs | Three-way valve | 24VAC N=Neutral Open, Close=direction (For circuit switching when connected to DHW tank) |
| | Two-way valve | 24VAC N=Neutral Open, Close (Prevent water circuit pass through during cooling mode) |
| | Extra pump | 120VAC (Used when Mono bloc pump capacity is insufficient) |
| | Booster heater | 240VAC (Used when using booster heater in DHW tank) |
| | Boiler contact / Defrost signal | Dry contact (System setup necessary) |
| Thermistor Inputs | Outdoor air sensor | 5VDC |
| | Tank sensor | 5VDC |

6 Installation

Remote control outline

Figure 6-22 Remote Controller

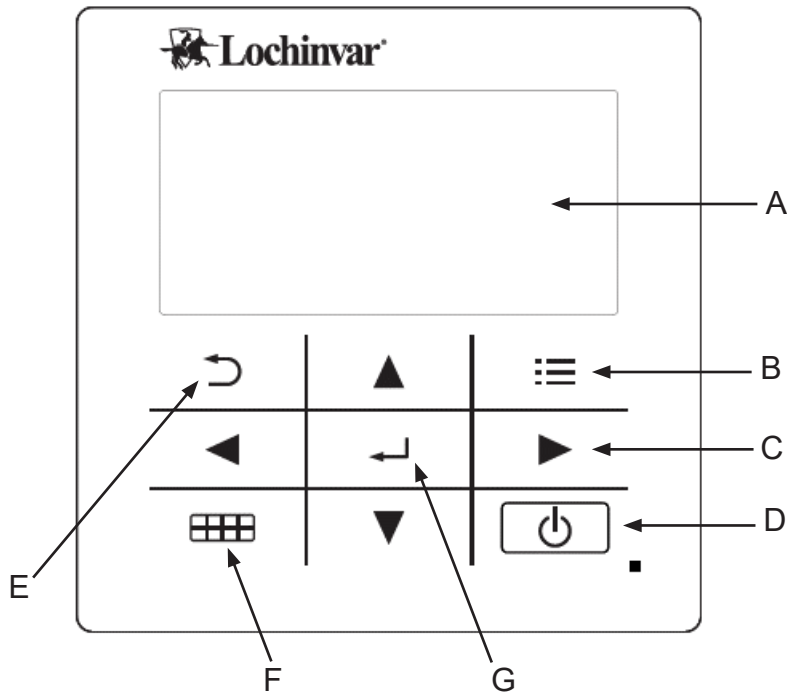

| DIAGRAM | NAME | FUNCTION |
|---------|-----------------|-----------------------|
| A | Main screen | Display information |
| B | Menu | Open/Close main menu |
| C | Triangle (Move) | Select or change item |
| D | Operate | Start/Stop operation |
| E | Back | Back to previous item |
| F | Quick Menu | Open/Close Quick menu |
| G | OK | Confirm |

6 Installation

Figure 6-23 Remote controller home screen

1: Function icon

| Name | Function |
|------------------|-----------------------------------|
| 1: Function icon | Display set function/status |
| [Icon] | Holiday mode |
| [Icon] | Weekly timer |
| [Icon] | Quiet mode |
| [Icon] | Remote controller room thermostat |
| [Icon] | Powerful mode |
| [Icon] | Room heater |
| [Icon] | Tank heater |
| [Icon] | Backup boiler |

2: Mode

Display set mode/current status of mode

- Heating
- Cooling
- Auto
- Hot water supply
- Heat pump operating
- Auto heating
- Auto cooling

3: Temp setting

Display set room temp

- Set room temp
- Compensation curve
- Set direct water temp

4: Display Heat temp

Display current heating temperature (it is set temperature when enclosed by line)

5: Display tank temp

Display current tank temperature (it is set temperature when enclosed by line)

6: Outdoor temp

Display outdoor temp

Figure 6-24 Remote Controller Initialization

Initialization 12:00am, Mon

Initializing.

When power is ON, firstly initialization screen appears (10 sec)

«

Date & time 12:00am, Mon

Year/Month/Day Hour : Min

2020 / 01 / 01 12 : 00

YY/MM/DD/Time setup screen appears

« Set YY/MM/DD/Time & confirm

«

12:00am, Mon

Back to initial screen

«

Press menu, select Installer setup

Language 12:00am, Mon

ENGLISH

FRANÇAIS

When any button is pressed, language setting screen appears. (NOTE) If initial setting is not performed, it does not go into menu.

« Set language & confirm

«

Main Menu 12:00am, Mon

System check

Personal setup

Service contact

Installer setup

Confirm to go into Installer setup

Clock format 12:00am, Mon

24h

am/pm

When language is set, setting screen of time display appears (24h/am/pm)

« Set time display & confirm

6 Installation

System setup

Figure 6-25 Remote controller flow chart

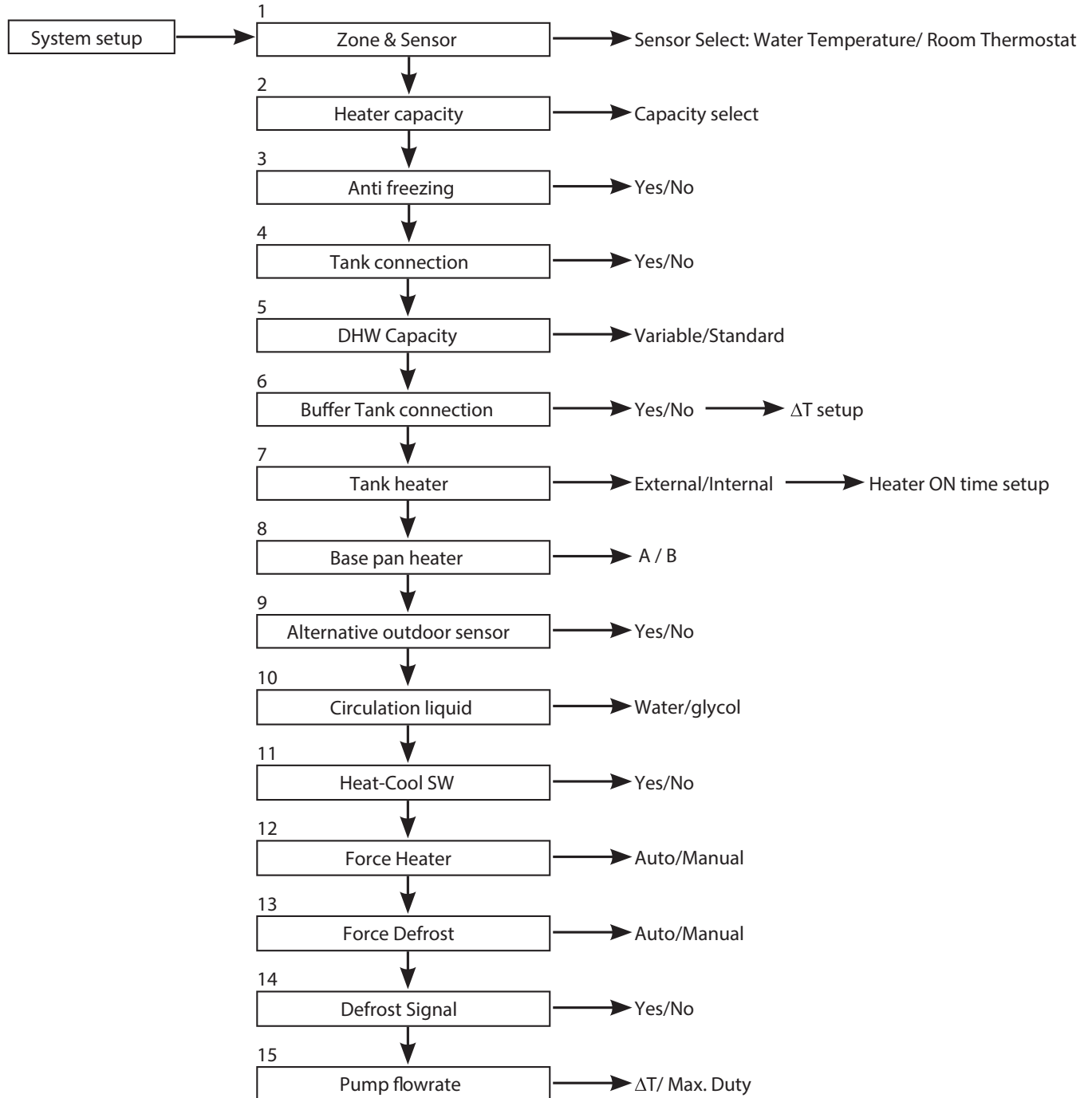

6 Installation

Operation setup

Figure 6-25 Remote controller flow chart continued

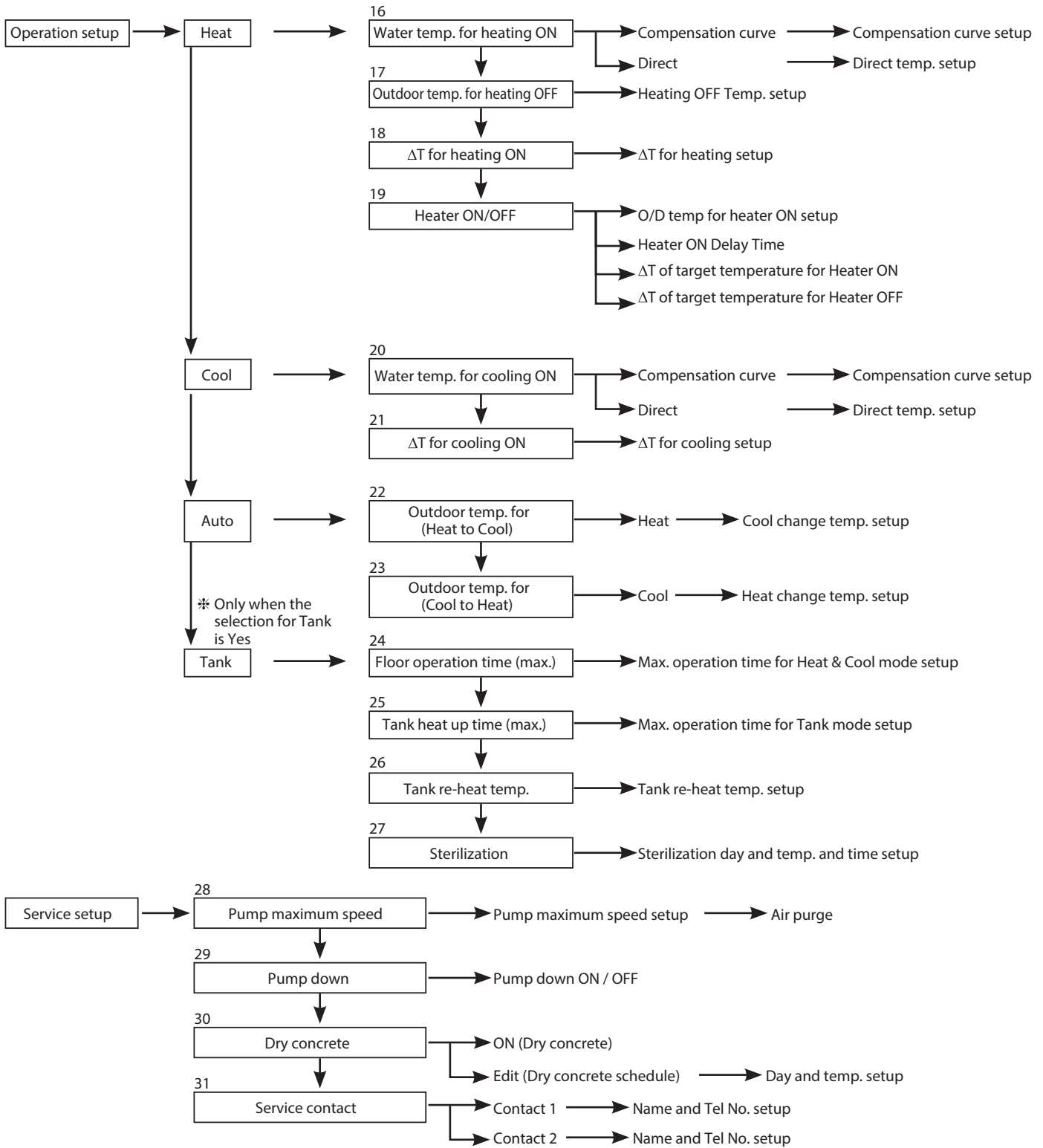

6 Installation

System setup

Figure 6-26 Remote controller settings

| | | | | | | | | | | | | | | |
|--|------------------------------|--|--------------|--------------|---------------|--|-----------------|--|---------------|--|-----------------|--|----------|-------------|
| 1. Zone & Sensor | Initial setting: Water temp. | <table border="1"> <tr><td>System setup</td><td>12:00am, Mon</td></tr> <tr><td>Zone & Sensor</td><td></td></tr> <tr><td>Heater capacity</td><td></td></tr> <tr><td>Anti freezing</td><td></td></tr> <tr><td>Tank Connection</td><td></td></tr> <tr><td>◆ Select</td><td>[←] Confirm</td></tr> </table> | System setup | 12:00am, Mon | Zone & Sensor | | Heater capacity | | Anti freezing | | Tank Connection | | ◆ Select | [←] Confirm |
| System setup | 12:00am, Mon | | | | | | | | | | | | | |
| Zone & Sensor | | | | | | | | | | | | | | |
| Heater capacity | | | | | | | | | | | | | | |
| Anti freezing | | | | | | | | | | | | | | |
| Tank Connection | | | | | | | | | | | | | | |
| ◆ Select | [←] Confirm | | | | | | | | | | | | | |
| <p>Select sensor of room temperature control from the following 2 items</p> <ol style="list-style-type: none"> 1 Water temperature (Circulation water temperature) 2 Room thermostat (Internal or External) | | | | | | | | | | | | | | |
| 2. Heater capacity | Initial setting: 6kW | <table border="1"> <tr><td>System setup</td><td>12:00am, Mon</td></tr> <tr><td>Zone & Sensor</td><td></td></tr> <tr><td>Heater capacity</td><td></td></tr> <tr><td>Anti freezing</td><td></td></tr> <tr><td>Tank Connection</td><td></td></tr> <tr><td>◆ Select</td><td>[←] Confirm</td></tr> </table> | System setup | 12:00am, Mon | Zone & Sensor | | Heater capacity | | Anti freezing | | Tank Connection | | ◆ Select | [←] Confirm |
| System setup | 12:00am, Mon | | | | | | | | | | | | | |
| Zone & Sensor | | | | | | | | | | | | | | |
| Heater capacity | | | | | | | | | | | | | | |
| Anti freezing | | | | | | | | | | | | | | |
| Tank Connection | | | | | | | | | | | | | | |
| ◆ Select | [←] Confirm | | | | | | | | | | | | | |
| <p>Set the selectable heater capacity.</p> | | | | | | | | | | | | | | |
| 3. Anti freezing | Initial setting: Yes | <table border="1"> <tr><td>System setup</td><td>12:00am, Mon</td></tr> <tr><td>Zone & Sensor</td><td></td></tr> <tr><td>Heater capacity</td><td></td></tr> <tr><td>Anti freezing</td><td></td></tr> <tr><td>Tank Connection</td><td></td></tr> <tr><td>◆ Select</td><td>[←] Confirm</td></tr> </table> | System setup | 12:00am, Mon | Zone & Sensor | | Heater capacity | | Anti freezing | | Tank Connection | | ◆ Select | [←] Confirm |
| System setup | 12:00am, Mon | | | | | | | | | | | | | |
| Zone & Sensor | | | | | | | | | | | | | | |
| Heater capacity | | | | | | | | | | | | | | |
| Anti freezing | | | | | | | | | | | | | | |
| Tank Connection | | | | | | | | | | | | | | |
| ◆ Select | [←] Confirm | | | | | | | | | | | | | |
| <p>Operate anti-freezing of water circulation circuit. If select Yes, when the water temperature is reaching its freezing temperature, the circulation pump will start up. If the water temperature does not reach the pump stop temperature, back-up heater will be activated.</p> <p>(NOTE) If set No, when the water temperature is reaching its freezing temperature or below 32°F, the water circulation circuit may freeze and cause malfunction.</p> | | | | | | | | | | | | | | |
| 4. Tank connection | Initial setting: No | <table border="1"> <tr><td>System setup</td><td>12:00am, Mon</td></tr> <tr><td>Zone & Sensor</td><td></td></tr> <tr><td>Heater capacity</td><td></td></tr> <tr><td>Anti freezing</td><td></td></tr> <tr><td>Tank connection</td><td></td></tr> <tr><td>◆ Select</td><td>[←] Confirm</td></tr> </table> | System setup | 12:00am, Mon | Zone & Sensor | | Heater capacity | | Anti freezing | | Tank connection | | ◆ Select | [←] Confirm |
| System setup | 12:00am, Mon | | | | | | | | | | | | | |
| Zone & Sensor | | | | | | | | | | | | | | |
| Heater capacity | | | | | | | | | | | | | | |
| Anti freezing | | | | | | | | | | | | | | |
| Tank connection | | | | | | | | | | | | | | |
| ◆ Select | [←] Confirm | | | | | | | | | | | | | |
| <p>Select whether it is connected to hot water tank or not. If set Yes, it becomes setting that uses hot water function. Hot water temperature of tank can be set from main screen.</p> | | | | | | | | | | | | | | |

6 Installation

Figure 6-26 Remote controller settings continued

5. DHW Capacity Initial setting: Variable

Variable DHW capacity setting normally run with efficient heating which is energy saving heating. But while hot water usage high and tank water temperature low, variable DHW mode will run with fast heat up which heat up the tank with high heating capacity. If standard DHW capacity setting is selected, heat pump run with heating rated capacity at tank heat up operation.

| | |
|---------------------------|--------------|
| System setup | 12:00am, Mon |
| Heater capacity | |
| Anti freezing | |
| Tank connection | |
| DHW Capacity | |
| ⬆ Select [↩] Confirm | |

6. Buffer Tank connection Initial setting: No

Select whether it is connected to buffer tank for heating or not. If buffer tank is used, please set Yes. Connect buffer tank thermistor and set, ΔT (ΔT use to increase primary side temp against secondary side target temp). If the buffer tank capacity is not so large, please set larger value for ΔT .

| | |
|---------------------------|--------------|
| System setup | 12:00am, Mon |
| Anti freezing | |
| Tank connection | |
| DHW Capacity | |
| Buffer tank connection | |
| ⬆ Select [↩] Confirm | |

7. Tank heater Initial setting: Internal

Select to use either built-in heater or external heater as heater for hot water tank. If heater is installed on tank, please select External.

Please set "Tank heater" to "ON" in the "Function setup" from remote controller when using heater to raise the tank temperature.

External A setting which is using booster heater installed on DHW tank to re-heat the tank. The permissible heater capacity is 10236 Btu/h and below. The operation to re-heat the tank with heater is as below. In addition, be sure to set suitable "Tank heater: ON time"

| | |
|---------------------------|--------------|
| System setup | 12:00am, Mon |
| Tank connection | |
| DHW Capacity | |
| Buffer tank connection | |
| Tank heater | |
| ⬆ Select [↩] Confirm | |

For 149°F setting

*This value is an example and for reference only. Real values may differ.

HP
Booster heater
Pump

Internal A setting which is using backup heater of Mono bloc to re-heat the tank. The operation to re-heat the tank with heater is as below.

For 149°F setting

*This value is an example and for reference only. Real values may differ.

HP
Backup heater
Pump

8. Base pan heater Initial setting: A

A: Turn on Heater when heating with defrost operation only
B: Turn on Heater at heating

| | |
|---------------------------|--------------|
| System setup | 12:00am, Mon |
| DHW Capacity | |
| Buffer tank connection | |
| Tank heater | |
| Base pan heater | |
| ⬆ Select [↩] Confirm | |

9. Alternative outdoor sensor Initial setting: No

Set Yes if outdoor sensor is installed. Controlled by optional outdoor sensor without reading the outdoor sensor of heat pump unit.

| | |
|----------------------------|--------------|
| System setup | 12:00am, Mon |
| Buffer tank connection | |
| Tank heater | |
| Base pan heater | |
| Alternative outdoor sensor | |
| ⬆ Select [↩] Confirm | |

6 Installation

Figure 6-26 Remote controller settings continued

10. BackupBoiler connection

Initial setting: No

Set if heat pump linked with boiler operation.
 Connect the start signal of the boiler in boiler contact terminal (main PCB).
 Set Backup Boiler connection to YES.
 After that, please begin setting according to remote controller instruction.
 Boiler icon will be displayed on remote controller top screen.

| | |
|----------------------------|--------------|
| System setup | 12:00am, Mon |
| Tank heater | |
| Base pan heater | |
| Alternative outdoor sensor | |
| Backup Boiler | |
| Select | [←] Confirm |

There are 3 different modes in the boiler operation. Movement of each modes are shown below.

- 1 Alternative (switch to boiler operation when drops below setting temperature)
- 2 Parallel (allow boiler operation when drops below setting temperature)
- 3 Advanced Parallel (able to slightly delay boiler operation time of parallel operation)

When the boiler operation is "ON", "boiler contact" is "ON", " _ "(underscore) will be displayed below the boiler icon.
 Please set target temperature of boiler to be the same as heat pump temperature.
 When boiler temperature is higher than heat pump temperature, zone temperature cannot be achieved if mixing valve is not installed.
 This product only allows one signal to control the boiler operation. Operation setting of boiler shall be responsible by installer.

Alternative mode

Parallel mode

Advanced Parallel mode

For heating

For DHW tank

AND

Although heat pump operates but water temperature does not reach this temperature for more than 30 mins (setting from remote controller)

AND

In Advanced Parallel mode, setting for both heating and tank can be made simultaneously. During operation of "Heating/Tank" mode, when each time the mode is switched, the boiler output will be reset to OFF. Please have good understanding on the boiler control characteristic in order to select the optimal setting for the system.

47

6 Installation

Figure 6-26 Remote controller settings continued

| | | | | | | | | | | | | | |
|---|---|--------------|--------------|----------------------------|--|--------------------------|--|--------------------|--|--------------------|--|----------|-------------|
| <div style="display: flex; justify-content: space-between; border: 1px solid black; padding: 2px;"> 11. Circulation Liquid Initial setting: Water </div> <p>Set circulation of heating water.</p> <p>There are 2 types of settings, water and glycol mixture.</p> <p>(NOTE) Please set glycol when using anti-freeze liquid. It may cause error if setting is wrong.</p> | <table border="1" style="width: 100%; border-collapse: collapse;"> <tr> <td style="text-align: right;">System setup</td> <td style="text-align: right;">12:00am, Mon</td> </tr> <tr> <td colspan="2">Base pan heater</td> </tr> <tr> <td colspan="2">Alternate outdoor sensor</td> </tr> <tr> <td colspan="2">Backup Boiler</td> </tr> <tr> <td colspan="2" style="background-color: #f0f0f0;">Circulation liquid</td> </tr> <tr> <td style="text-align: right;">▲ Select</td> <td style="text-align: right;">[↵] Confirm</td> </tr> </table> | System setup | 12:00am, Mon | Base pan heater | | Alternate outdoor sensor | | Backup Boiler | | Circulation liquid | | ▲ Select | [↵] Confirm |
| System setup | 12:00am, Mon | | | | | | | | | | | | |
| Base pan heater | | | | | | | | | | | | | |
| Alternate outdoor sensor | | | | | | | | | | | | | |
| Backup Boiler | | | | | | | | | | | | | |
| Circulation liquid | | | | | | | | | | | | | |
| ▲ Select | [↵] Confirm | | | | | | | | | | | | |
| <div style="display: flex; justify-content: space-between; border: 1px solid black; padding: 2px;"> 12. Heat-Cool SW Initial setting: Disable </div> <p>Able to switch (fix) heating & cooling by external switch.</p> <p>(Open) : Fix at Heating (Heating +DHW) (Short) : Fix at Cooling (Cooling +DHW)</p> <p>Timer function cannot be used. Cannot use Auto mode.</p> | <table border="1" style="width: 100%; border-collapse: collapse;"> <tr> <td style="text-align: right;">System setup</td> <td style="text-align: right;">12:00am, Mon</td> </tr> <tr> <td colspan="2">Alternative outdoor sensor</td> </tr> <tr> <td colspan="2">Backup Boiler</td> </tr> <tr> <td colspan="2">Circulation liquid</td> </tr> <tr> <td colspan="2" style="background-color: #f0f0f0;">Heat-Cool SW</td> </tr> <tr> <td style="text-align: right;">▲ Select</td> <td style="text-align: right;">[↵] Confirm</td> </tr> </table> | System setup | 12:00am, Mon | Alternative outdoor sensor | | Backup Boiler | | Circulation liquid | | Heat-Cool SW | | ▲ Select | [↵] Confirm |
| System setup | 12:00am, Mon | | | | | | | | | | | | |
| Alternative outdoor sensor | | | | | | | | | | | | | |
| Backup Boiler | | | | | | | | | | | | | |
| Circulation liquid | | | | | | | | | | | | | |
| Heat-Cool SW | | | | | | | | | | | | | |
| ▲ Select | [↵] Confirm | | | | | | | | | | | | |
| <div style="display: flex; justify-content: space-between; border: 1px solid black; padding: 2px;"> 13. Force Heater Initial setting: Manual </div> <p>Under manual mode, user can turn on force heater through quick menu.</p> <p>If selection is 'auto', force heater mode will turn automatically if pop up error happen during operation.</p> <p>Force heater will operate follow the latest mode selection, mode selection is disable under force heater operation.</p> <p>Heater source will ON during force heater mode.</p> | <table border="1" style="width: 100%; border-collapse: collapse;"> <tr> <td style="text-align: right;">System setup</td> <td style="text-align: right;">12:00am, Mon</td> </tr> <tr> <td colspan="2">External compressor SW</td> </tr> <tr> <td colspan="2">Circulation liquid</td> </tr> <tr> <td colspan="2">Heat-Cool SW</td> </tr> <tr> <td colspan="2" style="background-color: #f0f0f0;">Force Heater</td> </tr> <tr> <td style="text-align: right;">▲ Select</td> <td style="text-align: right;">[↵] Confirm</td> </tr> </table> | System setup | 12:00am, Mon | External compressor SW | | Circulation liquid | | Heat-Cool SW | | Force Heater | | ▲ Select | [↵] Confirm |
| System setup | 12:00am, Mon | | | | | | | | | | | | |
| External compressor SW | | | | | | | | | | | | | |
| Circulation liquid | | | | | | | | | | | | | |
| Heat-Cool SW | | | | | | | | | | | | | |
| Force Heater | | | | | | | | | | | | | |
| ▲ Select | [↵] Confirm | | | | | | | | | | | | |
| <div style="display: flex; justify-content: space-between; border: 1px solid black; padding: 2px;"> 14. Force Defrost Initial setting: Manual </div> <p>Under manual code, user can turn on force defrost through quick menu.</p> <p>If selection is 'auto', outdoor unit will run defrost operation once if heat pump have long hour of heating without any defrost operation before at low ambient condition. (Even auto is selected, user still can turn on force defrost through quick menu)</p> | <table border="1" style="width: 100%; border-collapse: collapse;"> <tr> <td style="text-align: right;">System setup</td> <td style="text-align: right;">12:00am, Mon</td> </tr> <tr> <td colspan="2">Circulation liquid</td> </tr> <tr> <td colspan="2">Heat-Cool SW</td> </tr> <tr> <td colspan="2">Force heater</td> </tr> <tr> <td colspan="2" style="background-color: #f0f0f0;">Force defrost</td> </tr> <tr> <td style="text-align: right;">▲ Select</td> <td style="text-align: right;">[↵] Confirm</td> </tr> </table> | System setup | 12:00am, Mon | Circulation liquid | | Heat-Cool SW | | Force heater | | Force defrost | | ▲ Select | [↵] Confirm |
| System setup | 12:00am, Mon | | | | | | | | | | | | |
| Circulation liquid | | | | | | | | | | | | | |
| Heat-Cool SW | | | | | | | | | | | | | |
| Force heater | | | | | | | | | | | | | |
| Force defrost | | | | | | | | | | | | | |
| ▲ Select | [↵] Confirm | | | | | | | | | | | | |
| <div style="display: flex; justify-content: space-between; border: 1px solid black; padding: 2px;"> 15. Defrost signal Initial setting: No </div> <p>Defrost signal sharing same terminal as boiler contact in main board. When defrost signal set to YES, boiler connection reset to NO. Only one function can be set between defrost signal and bivalent.</p> <p>When defrost signal set to YES, during defrost operation is running at outdoor unit defrost signal contact turn ON. Defrost signal contact turn OFF after defrost operation end. (Purpose of this contact output is to stop indoor fan coil or water pump during defrost operation).</p> | <table border="1" style="width: 100%; border-collapse: collapse;"> <tr> <td style="text-align: right;">System setup</td> <td style="text-align: right;">12:00am, Mon</td> </tr> <tr> <td colspan="2">Heat-Cool SW</td> </tr> <tr> <td colspan="2">Force heater</td> </tr> <tr> <td colspan="2">Force defrost</td> </tr> <tr> <td colspan="2" style="background-color: #f0f0f0;">Defrost signal</td> </tr> <tr> <td style="text-align: right;">▲ Select</td> <td style="text-align: right;">[↵] Confirm</td> </tr> </table> | System setup | 12:00am, Mon | Heat-Cool SW | | Force heater | | Force defrost | | Defrost signal | | ▲ Select | [↵] Confirm |
| System setup | 12:00am, Mon | | | | | | | | | | | | |
| Heat-Cool SW | | | | | | | | | | | | | |
| Force heater | | | | | | | | | | | | | |
| Force defrost | | | | | | | | | | | | | |
| Defrost signal | | | | | | | | | | | | | |
| ▲ Select | [↵] Confirm | | | | | | | | | | | | |
| <div style="display: flex; justify-content: space-between; border: 1px solid black; padding: 2px;"> 16. Pump flowrate Initial setting: ΔT </div> <p>If pump flowrate setting is ΔT, unit adjust pump duty to get different of water inlet and outlet base on setting on * ΔT for heating ON and * ΔT for cooling ON in operation setup menu during room side operation.</p> <p>If pump flowrate setting is set to Max. duty, unit will set the pump duty to the set duty at *Pump maximum speed in service setup menu during room side operation.</p> | <table border="1" style="width: 100%; border-collapse: collapse;"> <tr> <td style="text-align: right;">System setup</td> <td style="text-align: right;">12:00am, Mon</td> </tr> <tr> <td colspan="2">Force heater</td> </tr> <tr> <td colspan="2">Force defrost</td> </tr> <tr> <td colspan="2">Defrost signal</td> </tr> <tr> <td colspan="2" style="background-color: #f0f0f0;">Pump flowrate</td> </tr> <tr> <td style="text-align: right;">▲ Select</td> <td style="text-align: right;">[↵] Confirm</td> </tr> </table> | System setup | 12:00am, Mon | Force heater | | Force defrost | | Defrost signal | | Pump flowrate | | ▲ Select | [↵] Confirm |
| System setup | 12:00am, Mon | | | | | | | | | | | | |
| Force heater | | | | | | | | | | | | | |
| Force defrost | | | | | | | | | | | | | |
| Defrost signal | | | | | | | | | | | | | |
| Pump flowrate | | | | | | | | | | | | | |
| ▲ Select | [↵] Confirm | | | | | | | | | | | | |

6 Installation

Figure 6-26 Remote controller settings continued

17. Water temp. for heating ON Initial setting: compensation curve

Set target water temperature to operate heating operation.
 Compensation curve: Target water temperature change in conjunction with outdoor ambient temperature change.
 Direct: Set direct circulation water temperature.
 Regardless of the above setting, the water temperature will be limited as follows.

| Outdoor temperature | Maximum water temperature limit |
|---------------------|---------------------------------|
| -4°F | 131°F |
| 5 ~ 32°F | 140°F |
| 41~ 68°F | 149°F |
| 77~ 95°F | 140°F |

However, only when ΔT is set to 27°F, the water temperature setting of 141°F or higher will take effect.

Hot water temperature: 131°F, 95°F
 Outdoor temperature: 23°F, 59°F
 Decide temperature of 4 points as shown in diagram
 compensation curve

18. Outdoor temp. for heating OFF Initial setting: 75°F

Set outdoor temp to stop heating.
 Setting range is 41°F ~ 95°F

ON
 OFF
 75°F

19. ΔT for heating ON Initial setting: 9°F

Set temp difference between out temp & return temp of circulating water of Heating operation.
 When temp gap is enlarged, it is energy saving but less comfort. When the gap gets smaller, energy saving effect gets worse but it is more comfortable.
 Setting range is 2°F ~ 27°F

Out →
 ← Return
 Out — Return = 2°F ~ 27°F

20. Heater ON/OFF

a. Outdoor temp. for heater ON Initial setting: 32°F

Set outdoor temp when back-up heater starts to operate.
 Setting range is -4°F ~ 59°F
 User shall set whether to use or not to use heater.

b. Heater ON delay time Initial setting: 30 minutes

Set delay time from compressor ON for heater to turn ON if not achieve water set temperature.
 Setting range is 10 minutes ~ 60 minutes

c. Heater ON: ΔT of target Temp Initial setting: -7°F

Set water temperature for heater to turn on at heat mode.
 Setting range is -18°F ~ -4°F

d. Heater OFF: ΔT of target Temp Initial setting: -4°F

Set water temperature for heater to turn off at heat mode.
 Setting range is -6°F ~ 0°F

ON
 OFF
 32°F

Heater ON
 Compressor ON
 0 : 30

Water Set Temp.
 Heater OFF -4°F
 Heater ON -7°F

6 Installation

Figure 6-26 Remote controller settings continued

| | | |
|---|--|---------------------------|
| <p>21. Water temp. for cooling ON</p> | <p>Initial setting: Compensation curve</p> | <p>compensation curve</p> |
| <p>Set target water temperature to operate cooling operation. Compensation curve: Target water temperature change in conjunction with outdoor ambient temperature change. Direct: Set direct circulation water temperature.</p> | | |
| <p>22. ΔT for cooling ON</p> | <p>Initial setting: 9°F</p> | |
| <p>Set temp difference between out temp & return temp of circulating water of Cooling operation. When temp gap is enlarged, it is energy saving but less comfort. When the gap gets smaller, energy saving effect gets worse but it is more comfortable. Setting range is 2°F ~ 27°F</p> | | |
| <p>23. Outdoor temp. for (Heat to Cool)</p> | <p>Initial setting: 59°F</p> | |
| <p>Set outdoor temp that switches from heating to cooling by Auto setting. Setting range is 41°F ~ 77°F Timing of judgement is every 1 hour</p> | | |
| <p>24. Outdoor temp. for (Cool to Heat)</p> | <p>Initial setting: 50°F</p> | |
| <p>Set outdoor temp that switches from Cooling to Heating by Auto setting. Setting range is 41°F ~ 77°F Timing of judgement is every 1 hour</p> | | |
| <p>25. Floor operation time (max.)</p> | <p>Initial setting: 8h</p> | |
| <p>Set max operating hours of heating. When max operation time is shortened, it can boil the tank more frequently. It is a function for Heating + Tank operation.</p> | | |
| <p>26. Tank heat up time (max.)</p> | <p>Initial setting: 60min</p> | |
| <p>Set max boiling hours of tank. When max boiling hours are shortened, it immediately returns to Heating operation, but it may not fully boil the tank.</p> | | |
| <p>27. Tank re-heat temp.</p> | <p>Initial setting: -14°F</p> | |
| <p>Set temp to perform reboil of tank water. Setting range is -21°F ~ -4°F</p> | | |
| <p>28. Sterilization</p> | <p>Initial setting: 149°F 10min</p> | |
| <p>Set timer to perform sterilization. ① Set operating day & time. (Weekly timer format) ② Sterilization temp (131°F ~ 167°F * If use back-up heater, it is 149°F) ③ Operation time (Time to run sterilization when it reached setting temp 5min ~ 60min) User shall set whether to use or not to use sterilization mode.</p> | | |

6 Installation

Figure 6-26 Remote controller settings continued

29. Pump maximum speed

Normally setting is not necessary.
Please adjust when need to reduce the pump sound etc.
Besides that, it has Air Purge function.
When *Pump flow setting is Max. Duty, this duty set is the fix pump duty run during room side operation.

| | | |
|---------------|-----------|--------------|
| Service setup | | 12:00am, Mon |
| Flow rate | Max. Duty | Operation |
| 0.00 gal/min | 0x00 | ▲ Air Purge |
| ◀ Select | | |

30. Pump down

Operate pump down operation

| | | |
|---------------|--|--------------|
| Service setup | | 12:00am, Mon |
| Pump down: | | |
| ON | | |
| [←] Confirm | | |

Pump down operation
in progress!

[⏻] OFF

31. Dry concrete

Operate concrete curing operation.
Select Edit, set temp for every stage (1~99 1 is for 1 day).
Setting range is 77~131°F
When it is turned ON, dry concrete starts.

| | | | | | |
|------|------|-------|-------|-------|------|
| 86°F | 95°F | 104°F | 113°F | 104°F | 95°F |
| ① | ② | ③ | ④ | ⑤ | ⑥ |

→ Stage

32. Service contact

Able to set name & tel no. of contact person when there is breakdown etc. or client has trouble. (2 items)

| | | |
|------------------|--|--------------|
| Service setup | | 12:00am, Mon |
| Service contact: | | |
| Contact 1 | | |
| Contact 2 | | |
| ▲ Select | | [←] Confirm |

| | |
|--------------------------------------|------------|
| Contact-1: Bryan Adams | |
| ABC/ abc | 0-9/ Other |
| A B C D E F G H I J K L M N O P Q R | |
| S T U V W X Y Z a b c d e f g h i | |
| j k l m n o p q r s t u v w x y z | |
| ▼ Select | [←] Enter |

7 Maintenance Guide

In order to ensure safety and optimal performance of the unit, seasonal inspections on the unit, functional check of RCCB/ELCB, field wiring and piping have to be carried out at regular intervals. This maintenance should be carried out by a qualified installer or technician. Contact the manufacturer for scheduled inspection.

Air purge valve

Make sure all the piping installations are properly done before carrying out the steps below.

1. Open Cabinet front plate to access to the Pressure Relief Valve and Air Purge Valve.
2. Turn the plug on the Air Purge Valve outlet counterclockwise by one complete turn from fully closed position.
3. Set the Pressure Relief Valve level "DOWN".
4. Start filling water (with pressure more than 14.5 PSI) to the Mono bloc unit via water inlet. Stop filling water if the free water flow through Pressure Relief Valve drain hose.
5. Turn ON the power supply and make sure Water Pump is running.
6. Check and make sure no water leaking at the tube connecting points.
7. Reinstall the Cabinet front plate by tightening the two mounting screws.

Water pressure *(14.5 PSI)

Water pressure should not lower than 7.3 PSI (with inspects the Water Pressure Gauge). If necessary add tap water into the water circuit.

Pressure relief valve

1. Check for correct operation of the Pressure Relief Valve by turning on the lever to become horizontal.
2. If you do not hear a clacking sound (due to water drainage), contact your local a qualified installer or technician.
3. Push down the lever after finish checking.
4. In case the water keeps drained out from the unit, switch off the system, and then contact your local a qualified installer or technician.

Expansion vessel

The Mono bloc unit has a built-in Expansion Vessel with 2.64 gal air capacity and initial pressure of 14.5 PSI.

Without an antifreeze agent condition, the total amount of water in the system should be below 52.8 gal. If the total amount of water is more than 52.8 gal, please add expansion vessel (field supply).

With antifreeze agent condition, the expansion rate is different depending on its maker. Please refer to the antifreeze agent maker for the expansion rate before calculating the upper limit water volume of the system.

RCCB

Ensure the RCCB is set to "ON" before checking the RCCB. Turn on the power supply to the Mono bloc unit. This testing can only be done when power is supplied to the Mono bloc unit.

1. Push the "TEST" button on the RCCB. The lever would turn down and indicate "0", if it functions normal.
2. Contact a qualified installer or technician if the RCCB malfunction.
3. Turn off the power supply to the Mono bloc unit.
4. If RCCB functions normal, set the lever to "ON" again after testing finish.

This product contains fluorinated greenhouse gasses.

Refrigerant type : R32 (GWP=675)

For RAH040

Amount : 3.53 lbs (1.080 ton CO2 equivalent)

Test run

Before doing a test run, make sure the below items have been checked:

- Pipework is properly done.
- Electric cable connecting work are properly done.
- Mono bloc unit is filled up with water and trapped air is released. Antifreeze agent must be added into water circuit to prevent freezing of water when outdoor ambient temperatures is low.

Recommended antifreeze: Propylene glycol: 40% (equivalent to -4°F)

Turn ON to the Mono bloc unit and RCCB 2. Then, for remote control operation, please refers to (Mono bloc) Air-to-Water Heatpump's operation instruction. For normal operation, Water Pressure Gauge reading should be in between 7.3 PSI and 43.5 PSI. After a test run, please clean the Magnetic Water Filter Set. Reinstall it after cleaning.

Water flow of water circuit

Confirm the maximum water flow during main pump operation is not less than 3.96 gal/min.

*Water flow can be checked through service setup (Pump Max Speed) [Heating operation at low water temperature with lower water flow may trigger "H75" during defrost process.]

7 Maintenance Guide

Reset overload protector

Overload Protector serves the safety purpose to prevent the water over heating. When the Overload Protector trips at high water temperature, take below steps to reset it.

- Take out the cover.
- Use a test pen to push the centre button gently in order to reset the Overload Protector.
- Fix the cover to the original fixing condition.

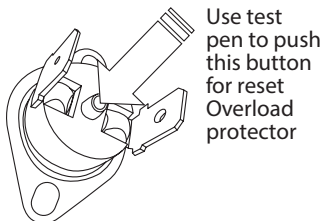

Maintenance Menu

Service and maintenance

If forget Password and cannot operate remote controller

Press $\leftarrow + \rightarrow + \rightarrow$ for 5 sec.
 Password unlock screen appears, press Confirm and it shall reset.
 Password will become 0000. Please reset it again.
 (NOTE) Only display when it is locked by password.

Maintenance Menu

Setting method of Maintenance menu

| | |
|------------------|--------------|
| Maintenance menu | 12:00am, Mon |
| Actuator check | |
| Test mode | |
| Sensor setup | |
| Reset password | |
| ▼ Select | [↵] Confirm |

Press $\leftarrow + \rightarrow + \rightarrow$ for 5 sec.

Items that can be set

- Actuator check (Manual ON/OFF all functional parts)
 (NOTE) As there is no protection action, please be careful not to cause any error when operating each part (do not turn on pump when there is no water etc.)
- Test mode (Test run)
 Normally it is not used.
- Sensor setup (offset gap of detected temp of each sensor within -3 ~ 3°F range)
 (NOTE) Please use only when sensor is deviated.
 It affects temperature control.
- Reset password (Reset password)

Custom Menu

Setting method of Custom menu

| | |
|-------------------------|--------------|
| Custom menu | 12:00am, Mon |
| Cool mode | |
| Back-up heater | |
| Reset energy monitor | |
| Reset operation history | |
| ▼ Select | [↵] Confirm |

Please press $\left[\text{Menu} \right] + \blacktriangledown + \blacktriangleleft$ for 10 sec.

Items that can be set

- Cool mode (Set With/Without Cooling function) Default is with
 (NOTE) As with/without Cool mode may affect electricity application, please be careful and do not simply change it.
 In Cool mode, please be careful if piping is not insulated properly, dew may form on pipe and water may drip on the floor and damage the floor.
- Backup heater (Use/Do not use Backup heater)
 (NOTE) It is different from to use/not to use backup heater set by client. When this setting is used, heater power on due to protection against frost will be disabled. (Please use this setting when it is required by utility company.)
 By using this setting, it cannot defrost due to low Heating's setting temp and operation may stop (H75)
 Please set under the responsibility of installer.
 When it stops frequently, it may be due to insufficient circulation flow rate, setting temp of heating is too low etc.
- Reset energy monitor (delete memory of Energy monitor)
 Please use when moving house and handover the unit.
- Reset operation history (delete memory of operation history).
 Please use when moving house and handover the unit.

Specifications

Table 7-1 Specifications of fresh water was heat transfer medium in brazed heat exchanger

| Parameter | Quality Limits for Tap Water on the Secondary Side |
|--------------|---|
| Temperature | Below 140°F |
| pH | 7 to 9 |
| Alkalinity | 0.0005 lbs/gal <HCO ₃ <0.0025 lbs/gal |
| Conductivity | < 1.26 mS/in |
| Hardness | [Ca ⁺ , Mg ⁺] / [HCO ₃ ⁻] > 5 |
| Chloride | < 0.0017 lbs/gal at 140°F |
| Sulphate | [SO ₄ ²⁻] > 0.0008 lbs/gal and [HCO ₃ ⁻] / [SO ₄ ²⁻] > 1 |
| Nitrate | NO ₃ < 0.0008 lbs/gal |
| Chlorine | < 0.000004 lbs/gal |

External filter

Solids in the water must be filtered. Minimum filter mesh size required for the field supply external filter in the water inlet is 20 mesh.

8 Troubleshooting Guide

Refrigeration Cycle System

In order to diagnose malfunctions, make sure that there are no electrical problems before inspecting the refrigeration cycle. Such problems include insufficient insulation, problem with the power source, or malfunction of a compressor and a fan. The normal pressure of the refrigeration cycle depends on various conditions, the standard values for them are shown in table 8-1.

Table 8-1 Standard Pressure

| | Gas pressure PSI |
|--------------|------------------|
| Heating Mode | 333.6 ~ 420.6 |
| Cooling Mode | 130.5 ~ 174 |

*Conditions: Outdoor temperature 44.6°F at heating mode and 95°F at cooling mode. Compressor operates at rated frequency.

Figure 8-1 Electric Current during operation

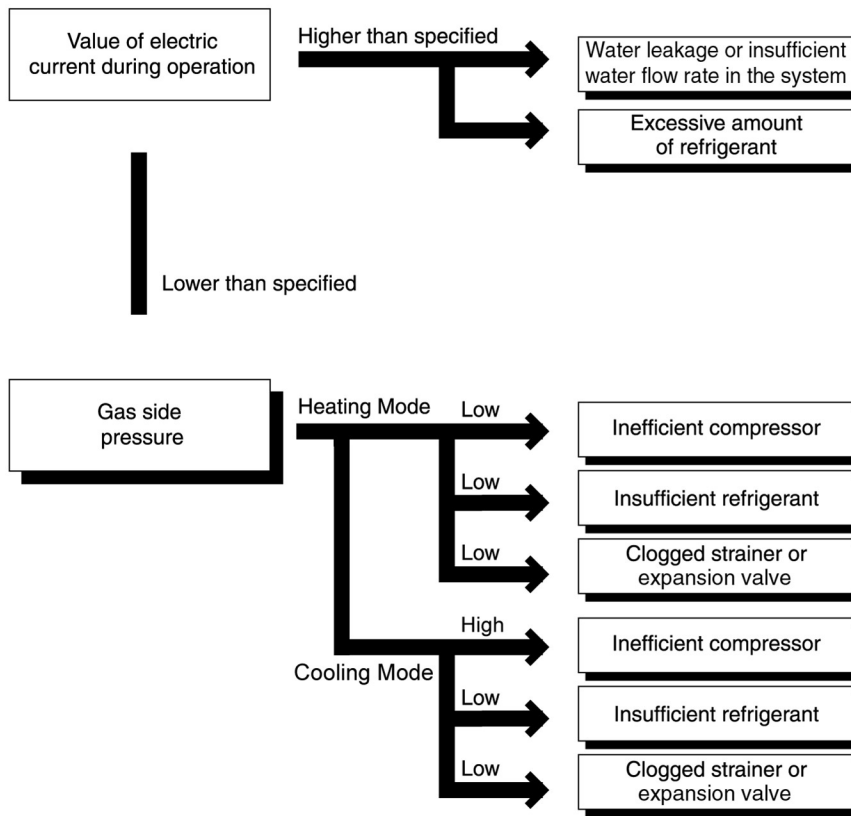

- Measuring electric current during operation

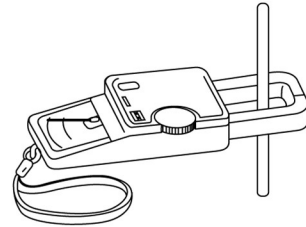

- Measuring gas side pressure

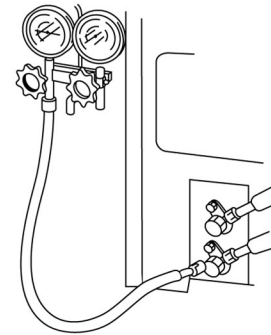

8 Troubleshooting Guide

Table 8-2 Relationship between the Condition of the Air-to-Water Heatpump Indoor and Outdoor Units, Pressure, and Electric Current

| Condition of the Air-to-Water Heat pump indoor and outdoor units | Heating Mode | | | Cooling Mode | | |
|--|--------------|---------------|-----------------------------------|--------------|---------------|-----------------------------------|
| | Low Pressure | High Pressure | Electric current during operation | Low Pressure | High Pressure | Electric current during operation |
| Water leakage or insufficient water flow rate in the system | ➔ | ➔ | ➔ | ➔ | ➔ | ➔ |
| Excessive amount of refrigerant | ➔ | ➔ | ➔ | ➔ | ➔ | ➔ |
| Inefficient compression | ➔ | ➔ | ➔ | ➔ | ➔ | ➔ |
| Insufficient refrigerant (gas leakage) | ➔ | ➔ | ➔ | ➔ | ➔ | ➔ |
| Outdoor heat exchange deficiency | ➔ | ➔ | ➔ | ➔ | ➔ | ➔ |
| Clogged expansion valve or Strainer | ➔ | ➔ | ➔ | ➔ | ➔ | ➔ |

*Carry out the measurements of pressure, electric current, and temperature fifteen minutes after an operation is started.

Breakdown Self Diagnosis Function

Self Diagnosis Function (Three Digits Alphanumeric Code)

When an abnormality occurs during operation, the system will stop operation, the OFF/ON control panel LED will blink, and an error code will display on the control panel. The error code is reset by turning OFF power supply or by selecting ERROR RESET. If the system abnormality is still showing, the system will again stop operation, and the OFF/ON control panel LED will blink again, and an error code will be display. The error code will be stored in the IC memory.

To check the error code

When an abnormality occurs, systems will stop operation and the OFF/ON control panel LED will blink. The error code of the abnormality will be displayed on the control panel. To determine the abnormality description, refer to the error code table.

To display past/last error code

Turn ON power supply. Refer to the following procedures to retrieve the error code history.

To permanently delete error code from IC memory

Turn ON power supply. Refer to the following procedures to clear error history.

8 Troubleshooting Guide

Figure 8-2 Locate error code

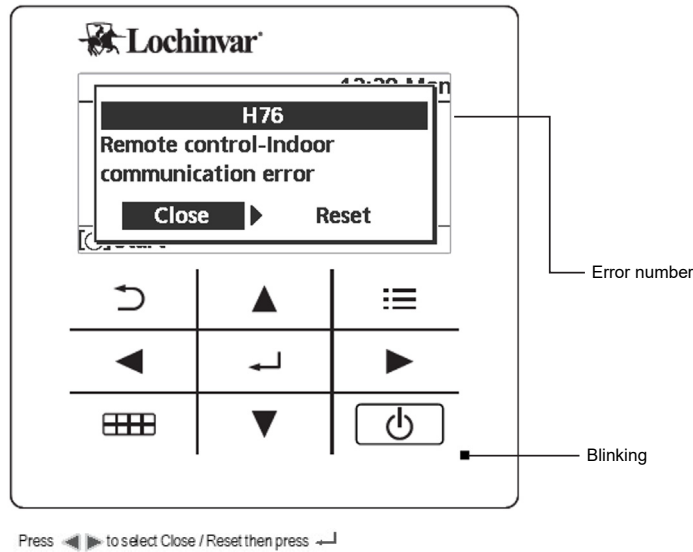
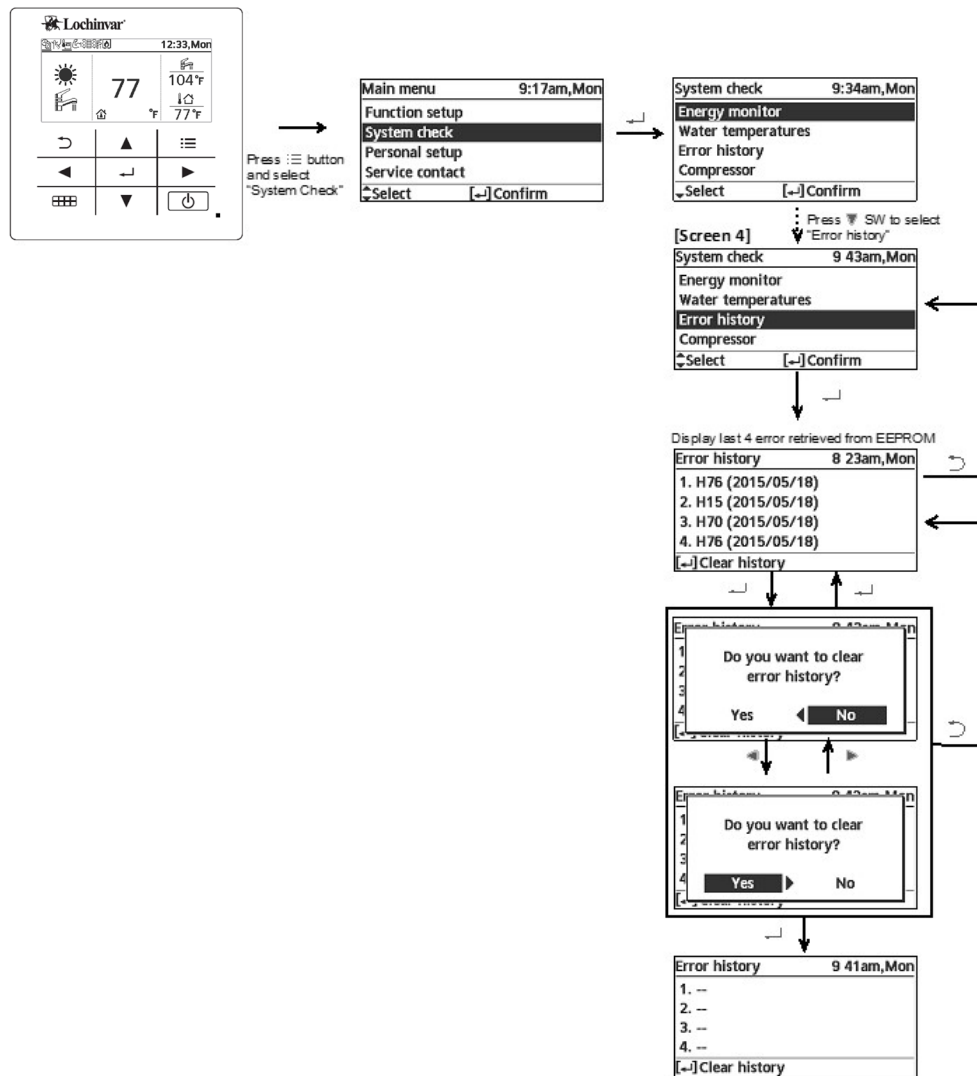

Figure 8-3 Display past/ last error code



8 Troubleshooting Guide

Table 8-3 Error chart

| Diagnosis display | Abnormality/Protection control | Abnormality judgement | Primary location to verify |
|-------------------|--|--|---|
| H00 | No abnormality detected | - | - |
| H12 | Indoor/Outdoor capacity unmatched | 90s after power supply | <ul style="list-style-type: none"> Indoor/outdoor connection wire Indoor/outdoor PCB Specification and combination table in catalogue |
| H15 | Outdoor compressor temperature sensor abnormality | Continue for 5 sec. | <ul style="list-style-type: none"> Compressor temperature sensor (defective or disconnected) |
| H20 | Water pump abnormality | Continue for 10 sec. | <ul style="list-style-type: none"> Indoor PCB Water pump (malfunction) |
| H23 | Indoor refrigerant liquid temperature sensor abnormality | Continue for 5 sec. | <ul style="list-style-type: none"> Refrigerant liquid temperature sensor (defective or disconnected) |
| H27 | Service valve error | Continue for 5 minutes | <ul style="list-style-type: none"> High pressure sensor (defective or disconnected) |
| H36 | Abnormal buffer tank sensor | Continue for 5 sec. | <ul style="list-style-type: none"> Buffer tank sensor (defective or disconnected) |
| H42 | Compressor low pressure abnormality | - | <ul style="list-style-type: none"> Outdoor pipe temperature sensor Clogged expansion valve or strainer Insufficient refrigerant Outdoor PCB Compressor |
| H62 | Water flow switch abnormality | Continue for 1 min. | <ul style="list-style-type: none"> Water flow switch |
| H64 | Refrigerant high pressure abnormality | Continue for 5 sec. | <ul style="list-style-type: none"> Outdoor high pressure sensor (defective or disconnected) |
| H65 | Abnormal de-ice water circulation | water flow > 1.8 gal/min continuously for 20 seconds during anti freeze de-ice | <ul style="list-style-type: none"> Water pump |

8 Troubleshooting Guide

Table 8-3 Error chart continued

| Diagnosis display | Abnormality/Protection control | Abnormality judgement | Primary location to verify |
|-------------------|--|---|---|
| H70 | Back-up heater OLP abnormality | Continue for 60 sec. | <ul style="list-style-type: none"> Back-up heater OLP (Disconnection or activated) |
| H72 | Tank sensor abnormal | Continue for 5 sec. | <ul style="list-style-type: none"> Tank sensor |
| H74 | PCB communication error | Communication or transfer error | <ul style="list-style-type: none"> Indoor main PCB and Sub PCB |
| H75 | Low water temperature control | Room heater disable and de-ice request to operate under low water temperature | <ul style="list-style-type: none"> Heater operation must enable to increase water temperature |
| H76 | Indoor - control panel communication abnormality | - | <ul style="list-style-type: none"> Indoor - control panel (defective or disconnected) |
| H90 | Indoor/outdoor abnormal communication | > 1 min after starting operation | <ul style="list-style-type: none"> Internal/external cable connections Indoor/Outdoor PCB |
| H91 | Tank heater OLP abnormality | Continue for 60 sec. | <ul style="list-style-type: none"> Tank heater OLP (Disconnection or activated) |
| H95 | Indoor/Outdoor wrong connection | - | <ul style="list-style-type: none"> Indoor/Outdoor supply voltage |
| H98 / F95 | Outdoor high pressure overload protection Cooling high pressure overload protection | - | <ul style="list-style-type: none"> Outdoor high pressure sensor Water pump or water leakage Clogged expansion valve or strainer Excess refrigerant Outdoor PCB |
| H99 | Indoor heat exchanger freeze prevention | - | <ul style="list-style-type: none"> Indoor heat exchanger Refrigerant shortage |
| F12 | Pressure switch activate | 4 times occurrence within 30 minutes | <ul style="list-style-type: none"> Pressure switch |
| F14 | Outdoor compressor abnormal revolution | 4 times occurrence within 20 minutes | <ul style="list-style-type: none"> Outdoor compressor |
| F15 | Outdoor fan motor lock abnormality | 2 times occurrence within 30 minutes | <ul style="list-style-type: none"> Outdoor PCB Outdoor fan motor |
| F16 | Total running current protection | 3 times occurrence within 20 minutes | <ul style="list-style-type: none"> Excess refrigerant Outdoor PCB |
| F20 | Outdoor compressor overheating protection | 4 times occurrence within 30 minutes | <ul style="list-style-type: none"> Compressor tank temperature sensor Clogged expansion valve or strainer Insufficient refrigerant Outdoor PCB Compressor |

8 Troubleshooting Guide

Table 8-3 Error chart continued

| Diagnosis display | Abnormality/Protection control | Abnormality judgement | Primary location to verify |
|-------------------|---|--------------------------------------|---|
| F22 | IPM (power transistor) overheating protection | 3 times occurrence within 30 minutes | <ul style="list-style-type: none"> Improper heat exchange IPM (Power transistor) |
| F23 | Outdoor Direct Current (DC) peak detection | 7 times occurrence continuously | <ul style="list-style-type: none"> Outdoor PCB Compressor |
| F24 | Refrigeration cycle abnormality | 2 times occurrence within 30 minutes | <ul style="list-style-type: none"> Insufficient refrigerant Outdoor PCB Compressor low compression |
| F25 | Cooling/Heating cycle changeover abnormality | 4 times occurrence within 30 minutes | <ul style="list-style-type: none"> 4-way valve V-coil |
| F27 | Pressure switch abnormality | Continue for 1 min. | <ul style="list-style-type: none"> Pressure switch |
| F30 | Water outlet sensor 2 abnormality | Continue for 5 sec. | <ul style="list-style-type: none"> Water outlet sensor 2 (defective or disconnected) |
| F32 | Abnormal Internal Thermostat | Continue for 5 sec. | <ul style="list-style-type: none"> Control panel PCB thermostat |
| F36 | Outdoor air temperature sensor abnormality | Continue for 5 sec. | <ul style="list-style-type: none"> Outdoor air temperature sensor (defective or disconnected) |
| F37 | Indoor water inlet temperature sensor abnormality | Continue for 5 sec. | <ul style="list-style-type: none"> Water inlet temperature sensor (defective or disconnected) |
| F40 | Outdoor discharge pipe temperature sensor abnormality | Continue for 5 sec. | <ul style="list-style-type: none"> Outdoor discharge pipe temperature sensor (defective or disconnected) |
| F41 | PFC control | 4 times occurrence within 10 minutes | <ul style="list-style-type: none"> Voltage at PFC |
| F42 | Outdoor heat exchanger temperature sensor abnormality | Continue for 5 sec. | <ul style="list-style-type: none"> Outdoor heat exchanger temperature sensor (defective or disconnected) |
| F43 | Outdoor defrost sensor abnormality | Continue for 5 sec. | <ul style="list-style-type: none"> Outdoor defrost sensor (defective or disconnected) |
| F45 | Indoor water outlet temperature sensor abnormality | Continue for 5 sec. | <ul style="list-style-type: none"> Water outlet temperature sensor (defective or disconnected) |
| F46 | Outdoor Current Transformer open circuit | - | <ul style="list-style-type: none"> Insufficient refrigerant Outdoor PCB Compressor low |
| F48 | Outdoor EVA outlet temperature sensor abnormality | Continue for 5 sec. | <ul style="list-style-type: none"> Outdoor EVA outlet temperature sensor (defective or disconnected) |
| F49 | Outdoor bypass outlet temperature sensor abnormality | Continue for 5 sec. | <ul style="list-style-type: none"> Outdoor bypass outlet temperature sensor (defective or disconnected) |

Revision Notes: *Revision A (PCP #3000065189 / CN #500051006) initial release.*

Revision B (PCP #3000070431 / CN #500055911) reflects updates to information throughout and additional logos.